

# Building Regulations 2010

## Technical Guidance Document M

### Access and Use

ARNA FHOILSIÚ AG OIFIG AN tSOLÁTHAIR  
BAILE ÁTHA CLIATH

Le ceannach díreach ón  
OIFIG DHÍOLTA FOILSEACHÁN RIALTAIS,  
TEACH SUN ALLIANCE, SRÁID THEACH LAIGHEAN, BAILE ÁTHA CLIATH 2,  
nó tríd an bpost ó  
FOILSEACHÁN RIALTAIS, AN RANNÓG POST-TRÁCHTA,  
AONAD 20 PÁIRC MIONDÍOLA COIS LOCHA, CLÁR CHLAINNE MHUIRIS, CONTAE MHAIGH EO  
(Teil: 01-6476834/37 nó 1890 213434; Fax: 01-6476843 nó 094-9378964)  
nó trí aon díoltóir leabhar.

---

PUBLISHED BY THE STATIONERY OFFICE  
DUBLIN

To be purchased directly from the  
GOVERNMENT PUBLICATIONS SALE OFFICE  
SUN ALLIANCE HOUSE, MOLESWORTH STREET, DUBLIN 2,  
or by mail order from  
GOVERNMENT PUBLICATIONS, POSTAL TRADE SECTION,  
UNIT 20 LAKESIDE RETAIL PARK, CLAREMORRIS, CO. MAYO  
(Tel: 01-6476834/37 or 1890 213434; Fax: 01-6476843 or 094-9378964)  
or through any bookseller.

---

Price € 12.00

ISBN 978-1-4064-2317-4



Printed on recycled paper containing a  
minimum of 75% post-consumer waste



**Comhshaol, Oidhreacht agus Rialtas Áitiúil**  
Environment, Heritage and Local Government

© Government of Ireland 2010

# Contents

---

	<b>Page</b>
Introduction	6
Transitional Arrangements	6
The Guidance	6
Existing Buildings	7
Technical Specifications	7
Materials and Workmanship	7
Interpretation	7
<b>Part M – The Requirement</b>	<b>9</b>
0.1 General	9
0.2 The Requirements	10
0.3 Buildings other than dwellings	10
0.4 Dwellings	10
0.5 Use of the Guidance	11
0.6 Application of Part M	11
0.7 Determination of practicability	13
0.8 Existing Buildings	14
0.9 Fire Safety	15
0.10 Diagrams	15
0.11 Disability Act 2005	15
0.12 Management	15
<b>Section 1 Access and Use of buildings other than dwellings</b>	<b>17</b>
<b>Section 1.1 Approach to buildings other than dwellings</b>	<b>18</b>
1.1.1 Objective	18
1.1.2 Introduction	18
1.1.3 Access routes	19
1.1.3.1 General	19
1.1.3.2 Level access routes	22
1.1.3.3 Gently sloped access routes	22
1.1.3.4 Ramped access routes	23
1.1.3.5 Stepped access routes	26
1.1.3.6 Handrails	31
1.1.4 Pedestrian crossings	34
1.1.5 On-site car parking	34
1.1.6 On-site setting down areas	37
<b>Section 1.2 Access to buildings other than dwellings</b>	<b>38</b>
1.2.1 Objective	38
1.2.2 Introduction	38
1.2.3 Accessible entrances	38
1.2.4 Accessible entrance doors	39
1.2.4.1 Accessible glass doors	43
1.2.4.2 Accessible manual doors	43

# Contents

---

1.2.4.3	Accessible power-operated doors	44
1.2.4.4	Low energy swing doors	45
1.2.5	Entrance lobbies	45
<b>Section 1.3</b>	<b>Circulation within buildings other than dwellings</b>	<b>47</b>
1.3.1	Objective	47
1.3.2	Introduction	47
1.3.3	Horizontal features	47
1.3.3.1	Reception area in entrance halls	47
1.3.3.2	Internal doors	49
1.3.3.3	Corridors and passageways	50
1.3.3.4	Internal lobbies	52
1.3.4	Vertical features	54
1.3.4.1	Provision	54
1.3.4.1.1	Lifts	54
1.3.4.1.2	Stairs	54
1.3.4.2	Passenger lift details	54
1.3.4.3	Internal stairs suitable for ambulant disabled people	57
1.3.4.4	Internal ramps	60
1.3.4.5	Handrails	60
<b>Section 1.4</b>	<b>Sanitary facilities for buildings other than dwellings</b>	<b>61</b>
1.4.1	Objective	61
1.4.2	Introduction	61
1.4.3	General provisions	61
1.4.3.1	Provisions for wheelchair accessible unisex WCs	62
1.4.3.2	Provisions for WC cubicles	62
1.4.3.3	Provisions for urinals	63
1.4.3.4	Provisions for accessible bathrooms/shower rooms	63
1.4.3.5	Provisions for changing and/or showering facilities	64
1.4.4	Sanitary facilities – General	64
1.4.5	Wheelchair accessible unisex WC	67
1.4.6	Cubicles	71
1.4.6.1	Standard cubicles	71
1.4.6.2	Cubicles for ambulant disabled people	72
1.4.6.3	Enlarged cubicles	72
1.4.7	Accessible urinals	74
1.4.8	Accessible bathrooms/shower rooms	76
1.4.9	Changing and/or showering facilities	80
1.4.9.1	Changing facilities	80
1.4.9.2	Showering facilities	80
<b>Section 1.5</b>	<b>Other facilities in buildings other than dwellings</b>	<b>83</b>
1.5.1	Objective	83
1.5.2	Introduction	83
1.5.3	Audience and spectator facilities with fixed seating	84

---

# Contents

---

1.5.4	Audience and spectator facilities without fixed seating	85
1.5.5	Refreshment facilities	88
1.5.6	Accessible sleeping accommodation	90
1.5.7	Switches, outlets and controls	91
<b>Section 1.6</b>	<b>Aids to communication</b>	<b>94</b>
1.6.1	Objective	94
1.6.2	Introduction	94
1.6.3	Signage	95
1.6.4	Visual contrast	95
1.6.5	Lighting	96
1.6.6	Audible aids	96
<b>Section 2</b>	<b>Access and Use of existing buildings other than dwellings</b>	<b>97</b>
2.0	Introduction	98
<b>Section 2.1</b>	<b>Approach to existing buildings other than dwellings</b>	<b>99</b>
2.1.1	Objective	99
2.1.2	Introduction	99
2.1.3	Access routes	99
2.1.3.1	General	99
2.1.3.2	Level access routes	99
2.1.3.3	Gently sloped access routes	99
2.1.3.4	Ramped access routes	100
2.1.3.5	Stepped access routes	101
2.1.3.6	Handrails	101
2.1.4	Pedestrian crossings	102
2.1.5	On-site car parking	102
2.1.6	On-site setting down areas	102
<b>Section 2.2</b>	<b>Access to existing buildings other than dwellings</b>	<b>102</b>
2.2.1	Objective	102
2.2.2	Introduction	102
2.2.3	Accessible entrances	102
2.2.4	Accessible entrance doors	102
2.2.4.1	Accessible glass doors	102
2.2.4.2	Accessible manual doors	102
2.2.4.3	Accessible power-operated doors	102
2.2.4.4	Low energy swing doors	102
2.2.5	Entrance lobbies	103
<b>Section 2.3</b>	<b>Circulation within existing buildings other than dwellings</b>	<b>103</b>
2.3.1	Objective	103
2.3.2	Introduction	103
2.3.3	Horizontal features	103
2.3.3.1	Reception area in entrance halls	103

# Contents

---

2.3.3.2	Internal doors	103
2.3.3.3	Corridors and passageways	103
2.3.3.4	Internal lobbies	103
2.3.4	Vertical features	103
2.3.4.1	Provision	103
2.3.4.1.1	Lifts	104
2.3.4.1.2	Stairs	104
2.3.4.2	Passenger lift details	104
2.3.4.3	Internal stairs suitable for ambulant disabled people	104
2.3.4.4	Internal ramps	105
2.3.4.5	Handrails	105
<b>Section 2.4 Sanitary facilities for existing buildings other than dwellings</b>		<b>105</b>
2.4.1	Objective	105
2.4.2	Introduction	105
2.4.3	General provisions	105
<b>Section 2.5 Other facilities in existing buildings other than dwellings</b>		<b>108</b>
2.5.1	Objective	108
2.5.2	Introduction	108
2.5.3	Audience and spectator facilities with fixed seating	108
2.5.4	Audience and spectator facilities without fixed seating	108
2.5.5	Refreshment facilities	108
2.5.6	Accessible sleeping accommodation	108
2.5.7	Switches, outlets and controls	108
<b>Section 2.6 Aids to communication</b>		<b>108</b>
2.6.1	Objective	108
2.6.2	Introduction	108
2.6.3	Signage	108
2.6.4	Visual contrast	108
2.6.5	Audible aids	108
<b>Section 3 Access and Use of dwellings</b>		<b>109</b>
<b>Section 3.1 Approach to dwellings</b>		<b>110</b>
3.1.1	Objective	110
3.1.2	Access route to a dwelling	110
3.1.2.1	General	110
3.1.2.2	Level access route	111
3.1.2.3	Gently sloped access route	111
3.1.2.4	Ramped access route	111
3.1.2.5	Stepped access route	111

# Contents

---

<b>Section 3.2 Access to dwellings</b>	<b>114</b>
3.2.1 Objective	114
3.2.2 Accessible entrance	114
<b>Section 3.3 Circulation within dwellings</b>	<b>115</b>
3.3.1 Objective	115
3.3.2 Circulation within a dwelling	115
3.3.2.1 Horizontal circulation within a dwelling	115
3.3.2.2 Vertical circulation within a dwelling	117
<b>Section 3.4 Sanitary facilities for dwellings</b>	<b>118</b>
3.4.1 Objective	118
3.4.2 Accessible WC	118
3.4.3 WC in smaller dwellings	120
<b>Section 3.5 Switches and sockets in dwellings</b>	<b>121</b>
3.5.1 Objective	121
3.5.2 Switches and sockets	121
<b>Standards and publications</b>	<b>122</b>
<b>Other standards and publications</b>	<b>124</b>

# Building Regulations 2010

## Technical Guidance Document M - Access and Use

---

### Introduction

This document has been published by the Minister for the Environment, Heritage and Local Government under article 7 of the Building Regulations 1997. It provides guidance in relation to Part M of the Second Schedule to the Regulations as amended by the Building Regulations (Part M Amendment) Regulations 2010 (S.I. No. 513 of 2010). The document should be read in conjunction with the Building Regulations 1997 - 2010 and other documents published under these Regulations.

In general, Building Regulations apply to the construction of new buildings and to extensions and material alterations to buildings. In addition, certain parts of the Regulations apply to existing buildings where a material change of use takes place. Otherwise, Building Regulations do not apply to buildings constructed prior to 1 June, 1992.

### Transitional Arrangements

In general, this document applies to works, or buildings in which certain material changes of use take place, where the works commence or the change of use takes place, as the case may be on or after 1 January 2012. Technical Guidance Document M – Access for People with Disabilities, dated 2000, also ceases to have effect from that date.

However, the latter document may continue to be used in the case of works, or buildings where –

- (a) the works commence or certain change of use takes place, as the case may be, on or before 31 December 2011, or

- (b) the works, or buildings are the subject of –
  - (i) a planning application made on or before 31 December 2011 for planning permission or approval pursuant to the Local Government (Planning and Development) Act 2000, and where substantial work has been completed by 31 December 2013, or
  - (ii) a notice pursuant to the provisions of Part 8 of the Local Government (Planning and Development) Regulations 2001 (S.I. No. 600 of 2001) has been published on or before 31 December 2011, and where substantial work has been completed by 31 December 2013, or
- (c) a Fire Safety Certificate or a Disability Access Certificate under the Building Control Regulations, in respect of the works or buildings, has been granted on or before 31 December 2011, and where substantial work has been completed by 31 December 2013.

“Substantial work has been completed” means that the structure of the external walls has been erected.

### The Guidance

The materials, methods of construction, standards and other specifications (including technical specifications) which are referred to in this document are those which are likely to be suitable for the purposes of the Regulations. Where works are carried out in accordance with



# Building Regulations 2010

## Technical Guidance Document M - Access and Use

---

the guidance in this document, this will, prima facie, indicate compliance with Part M of the Second Schedule to the Building Regulations (as amended). However, the adoption of an approach other than that outlined in the guidance is not precluded provided that the relevant requirements of the Regulations are complied with. Those involved in the design and construction of a building may be required by the relevant building control authority to provide such evidence as is necessary to establish that the requirements of the Building Regulations are being complied with.

### **Existing Buildings**

In the case of material alterations or change of use of existing buildings, the adoption without modification of the guidance in this document may not, in all circumstances, be appropriate. In particular, the adherence to guidance, including codes, standards or technical specifications, intended for application to new work may be unduly restrictive or impracticable. Buildings of architectural or historical interest are especially likely to give rise to such circumstances. In these situations, alternative approaches based on the principles contained in the document may be more relevant and should be considered.

### **Technical Specifications**

Building Regulations are made for specific purposes, e.g. to provide, in relation to buildings, for the health, safety and welfare of persons, the conservation of energy and access for people with disabilities. Technical specifications (including harmonised European Standards, European Technical Approvals, National Standards and Agrément Certificates) are relevant to the

extent that they relate to these considerations. Any reference to a technical specification is a reference to so much of the specification as is relevant in the context in which it arises. Technical specifications may also address other aspects not covered by the Regulations. A reference to a technical specification is to the latest edition (including any amendments, supplements or addenda) current at the date of publication of this Technical Guidance Document. However, if this version of the technical specification is subsequently revised or updated by the issuing body, the new version may be used as a source of guidance provided that it continues to address the relevant requirements of the Regulations.

A list of other standards and publications that deal with matters relating to this Part of the Building Regulations is included at the end of this document. These standards and publications may be used as a source of further information but do not form part of the guidance.

### **Materials and Workmanship**

Under Part D of the Second Schedule to the Building Regulations, building work to which the Regulations apply must be carried out with proper materials and in a workmanlike manner. Guidance in relation to compliance with Part D is contained in Technical Guidance Document D.

### **Interpretation**

In this document, a reference to a section, sub-section, part, paragraph or diagram is, unless otherwise stated, a reference to a section, sub-section, part, paragraph or diagram, as the case may be, of this document. A reference to

# Building Regulations 2010

## Technical Guidance Document M - Access and Use

---

another Technical Guidance Document is a reference to the latest edition of a document published by the Department of the Environment, Heritage and Local Government under Article 7 of the Building Regulations (as amended). Diagrams are used in this document to illustrate particular aspects of construction - they may not show all the details of construction.

# Access and Use

---

## Part M – The Requirement

Part M of the Second Schedule to the Building Regulations, (as amended), provides as follows:

Access and Use	M1	Adequate provision shall be made for people to access and use a building, its facilities and its environs.
Application of the Part	M2	Adequate provision shall be made for people to approach and access an extension to a building.
	M3	If sanitary facilities are provided in a building that is to be extended, adequate sanitary facilities shall be provided for people within the extension.
	M4	Part M does not apply to works in connection with extensions to and material alterations of existing dwellings, provided that such works do not create a new dwelling.

### 0.1 General

Part M aims to foster an inclusive approach to the design and construction of the built environment. The requirements of Part M (M1 - M4) aim to ensure that regardless of age, size or disability:

- (a) new buildings other than dwellings are accessible and usable;
- (b) extensions to existing buildings other than dwellings are where practicable, accessible and useable;
- (c) material alterations to existing buildings other than dwellings increase the accessibility and usability of existing buildings where practicable;
- (d) certain changes of use to existing buildings other than dwellings increase the accessibility and usability of existing buildings where practicable; and
- (e) new dwellings are visitable.

In doing so, the Requirements, underpin the principle of Universal Design. Universal design is defined in the Disability Act 2005 as “the design and composition of an environment so that it may be accessed, understood and used to the greatest practicable extent, in the most independent and natural manner possible, in the widest possible range of situations and without the need for adaptation, modification, assistive devices or specialised solutions, by persons of any age or size or having any particular physical, sensory, mental health or intellectual ability or disability.”

Buildings should be designed so that they are easy for people to use and to reflect the fact that all people experience changes in their abilities as they progress through the different stages of life. It is important for designers to take all of the users of buildings into account throughout the design process in order to avoid the creation of a built environment that excludes certain groups from participating in normal everyday activities.

# Access and Use

---

Experience has shown that meeting the needs of people with disabilities or elderly people frequently generates design solutions which benefit a wider range of user groups, including people with young children in buggies, people with temporary injuries or carrying heavy luggage.

This document, Technical Guidance Document M (TGD M) sets out guidance on the minimum level of provision to meet requirements M1-M4. However, those involved in the design and construction of buildings should also have regard to the design philosophy of Universal Design and consider making additional provisions where practicable and appropriate. For this purpose, a list of useful references, advocating greater accessibility, is given at the end of this document. Further advice and guidance can be found at the Centre for Excellence in Universal Design, [www.universaldesign.ie](http://www.universaldesign.ie) and in the publication 'Building for Everyone'.

## 0.2 The Requirements

In order to satisfy the requirements of Part M, all buildings should be designed and constructed so that:

- (a) people can safely and independently approach, gain access and use a building, its facilities and its environs, and
- (b) elements of the building do not constitute an undue hazard for people, especially for people with vision, hearing or mobility impairments.

## 0.3 Buildings other than dwellings

In the case of buildings other than dwellings, the building should also be designed and constructed so that:

- (a) people can circulate within the building and use the building's facilities;
- (b) where sanitary facilities are provided, adequate sanitary facilities are available and accessible to people with a range of abilities;
- (c) where relevant facilities such as fixed/ unfixed seating for audience or spectators, refreshment facilities, sleeping accommodation and the like are provided, adequate provision is made for people with a range of abilities;
- (d) suitable aids to communication are available for people with vision, hearing or mobility impairments.

## 0.4 Dwellings

Dwellings should be designed and constructed so that:

- (i) people can safely and conveniently approach and gain access. Where due to site specific constraints or where all entrances are on other than ground level and a suitable passenger lift is not provided, it is considered adequate to provide access by means of steps, or a stairway suitable for use by ambulant disabled people;
- (i) people can have access to the main habitable rooms at entry level. Where there is no habitable room at this level, it is considered adequate to provide for access to habitable rooms on the storey containing the main living room. Access to this storey from the entry storey may be by means of a stairway suitable for use by ambulant disabled people;

# Access and Use

---

- (iii) a WC is provided at entry level or, where there are no habitable rooms at this level, on the storey containing the main living room.

## 0.5 Use of the Guidance

Technical Guidance Document M 2010 is divided into 3 sections. Each section deals with different types of works.

**Section 1:** The guidance in Section 1 sets out the minimum level of provision for the following buildings to meet the requirements of M1:

- (a) buildings other than dwellings and their environs, and
- (b) the common areas of apartment blocks and their environs.

Section 1 applies to both new and existing buildings.

**Section 2:** The guidance in Section 2 should be read in conjunction with Section 1 and is intended to provide additional guidance for:

- (a) existing buildings other than dwellings and their environs; and
- (b) the common areas of existing apartment blocks and their environs.

Section 2 provides additional guidance on the minimum provisions for certain elements and features of existing buildings where it is not practicable (refer 0.7) to achieve the provisions set out in Section 1. Where works (e.g. extensions, material alterations and certain material changes of use, etc) to existing buildings are carried out in accordance with Section 1 and, where necessary Section 2, this will prima facie indicate compliance

with Requirement M1. Reference should be made to 0.6 and 0.8 for the application of Part M to existing buildings and 0.7 for considerations that should be made when determining 'practicability'.

**Section 3:** The guidance in Section 3 applies to dwellings and their environs. This includes individual dwelling houses and individual apartments. It does not apply to the common areas of apartment blocks. The guidance in Section 3 also applies to the common areas of duplex buildings.

## 0.6 Application of Part M

The Requirements of Part M apply to:

- (a) works in connection with new buildings and new dwellings;
- (b) works in connection with extensions to existing buildings, and in particular:
  - (i) under M2, adequate provision must be made to approach and access an extension. This may be provided by an adequate independent approach<sup>1</sup> and entrance to the extension, or where this is not practicable, the existing approach and entrance modified where necessary and where practicable, must provide adequate approach and access to the extension, and

---

<sup>1</sup>Independent approach means a route of access that does not require the user to pass through any other part of the building.

# Access and Use

---

- (i) under M3, where sanitary facilities are provided in a building, adequate accessible sanitary facilities must be provided for the people within the extension i.e. people using the extension. These may be provided by accessible sanitary facilities in the extension or alternatively, those facilities in the existing building, modified where necessary, must be adequate and accessible from the extension.
  
- (c) works in connection with material alterations of existing buildings. Building Regulations (Part M Amendment) Regulations 2010 (S.I. No. 513 of 2010), extends the definition of material alteration to include Part M. As a result, the Building Regulations apply to any alterations subject to the requirements of Part A, B or M. The incorporation of Part M means that alterations to features relevant to compliance with Part M e.g. entrances, sanitary facilities, etc, must comply with M1. The building as a whole, including the approach from the site boundary and from on-site car parking where provided, must be no less compliant with M1 following a material alteration of a building. However, this does not mean it is necessary to upgrade the existing access to the building entrance unless the entrance itself is subject to a material alteration;
  
- (d) an existing building or part of an existing building, which undergoes a material change of use to a day centre<sup>(i)</sup>, hotel, hostel or guest building<sup>(ii)</sup>, institutional building<sup>(iii)</sup>,

place of assembly<sup>(iv)</sup>, shop<sup>(v)</sup> (which is not ancillary to the primary use of the building) or shopping centre<sup>(vi)</sup>. S.I. No. 513 of 2010 amends Article 13 of the Building Regulations dealing with material changes of use to require Part M to apply to certain material changes of use. Where such material change of use applies to the whole building (including approach and access, where practicable), the building must comply with M1. Where such material change of use only applies to part of the building, that part must comply with M1, the approach and access to that part (through independent access or through another part of the building) where practicable (refer to 0.7) must comply with M1 and any sanitary facility provided in or in connection with it must comply with M1;

The Requirements of Part M do not apply to works in connection with extensions to and the material alterations of existing dwellings, provided that such works do not create a new dwelling. However, an extension or a material alteration of a dwelling must not make the building, as a whole, less satisfactory in relation to Part M than it was before. This means an extension or a material alteration of a dwelling need not itself comply with Part M, but it must not result in the dwelling being less compliant than it previously was;

Also, the Requirements of Part M do not apply to the part(s) of a building used solely to enable inspection, repair or maintenance.

# Access and Use

---

## Definitions relating to 0.6(d)

- (i) **Day centre** means a building used for the provision of treatment or care to persons where such persons do not stay overnight and includes a day care centre, crèche, pre-school and a day nursery.
- (ii) **Guest building** means a building (other than a hotel or hostel) providing overnight accommodation for reward, and includes a guest house.
- (iii) **Institutional building** includes a hospital, nursing home, home for old people or for children, school or other similar establishment used as living accommodation or for the treatment, care or maintenance of persons suffering from illness or mental or physical disability or handicap, where such persons sleep on the premises.
- (iv) **Place of assembly** includes:
- theatre, public library, hall or other building of public resort used for social or recreational purposes;
  - a non-residential school or other educational establishment;
  - a place of public worship;
  - a public house, restaurant or similar premises used for the sale to members of the public of food or drink for consumption on the premises,

but no building shall be treated as a place of assembly solely because it is a building to which members of the public are occasionally admitted.

(v) **Shop** includes a building used for retail or wholesale trade or business (including retail sales by auction, self selection and over-the-counter wholesale trading, the business of lending books or periodicals for gain and the business of a barber or hairdresser) and premises to which the public is invited to deliver or to collect goods in connection with their hire, repair or other treatment, or where they themselves may carry out such repairs or other treatments.

(vi) **Shopping centre** includes a building which comprises a number of individually occupied premises to which common access is provided principally for the benefit of shoppers.

---

## 0.7 Determination of practicability

In the determination of 'practicability' with respect to works to an existing building, its facilities or its environs the following non-exhaustive list of circumstances should be considered.

- Where the works would have a significant adverse effect on the historical significance of the existing building, facility or environs e.g. works to a Protected Structure<sup>2</sup>;
  - Where the existing structural conditions would require moving or altering a load bearing member which is an essential part of the overall structural stability of the building;
  - Where other existing physical or site constraints would prohibit modification of an existing feature;
- Where the works would need to be carried out on part of a building, its facilities or its environs that are not under the same control/ ownership e.g. in the case of a sub-leaseholder in a multi-occupancy building;
  - Where specific alternative guidance to Section 1 is provided in Section 2 and an existing feature or facility satisfies that guidance;
  - Where a specific planning condition prohibits modification of an identified existing feature.

---

<sup>2</sup> These buildings have been identified as having particular cultural significance and heritage value and are included by each Planning Authority on a Record of Protected Structures.

# Access and Use

---

## 0.8 Existing Buildings

Building Regulations do not apply to buildings subject to the National Monuments Acts 1930 to 2004.

0.6 sets out the application of Part M to buildings, new and existing.

The term 'practicability' is used in connection with works (e.g. material alterations and certain material changes of use) to existing buildings which identifies instances where achieving standards of accessibility associated with new buildings is not feasible because of particular circumstances. Refer to 0.7 for guidance on determining practicability.

Where works to existing buildings are carried out in accordance with the guidance in Section 1 of this document, this will, prima facie, indicate compliance with Part M. Where it is not practicable to apply the guidance in Section 1 and works are carried out to Section 2, this will also prima facie indicate compliance with Part M.

Works to existing buildings, such as extensions, material alterations and certain material changes of use, can present many design challenges because of the individual character, appearance and environs of existing buildings. The adoption without modification of the guidance in this document may not in all circumstances be appropriate. While each existing building and site will present its own unique access opportunities and constraints, which may result in different ways of addressing accessibility, the fundamental priorities of accessibility should be as set out in M1, i.e. accessing and using a building, its facilities and environs.

The application of this Part may pose particular challenges for buildings which are of architectural or historical interest. When considering works to an historic building, it is important to establish what is important or significant about the building. Historic buildings can be significant in many different ways, for example, in its physical fabric, in its historical associations or in its archaeological potential. The better the understanding of what is important, the easier it will be to design appropriate accessible solutions. Information about the significance of a building may be obtained from a conservation plan or statement, where these exist, or from the architectural conservation officer from the relevant local authority.

Historic buildings include Protected Structures, which are included by each Planning Authority on a Record of Protected Structures. These buildings have been identified as having particular cultural significance and heritage value.

As previously stated, the adoption without modification of the guidance in this document may not, in all circumstances, be appropriate for historic buildings. Liaison with the local Building Control Authority on alternative approaches based on the principles contained in this document may be more relevant and should be considered. In specific cases, a dispensation or relaxation (or partial dispensation or relaxation) of the Requirements may be granted by the local Building Control Authority.

Whilst the provisions of the Building Regulations do not relate to management, the role it can play in improving the accessibility of existing buildings is acknowledged. Designers/



# Access and Use

---

owners should be mindful of this and consider enhancing the accessibility of existing buildings through appropriate management solutions or compensating for existing buildings that have to apply for a (partial) dispensation or relaxation from Part M. For guidance on management refer to 0.12.

For more guidance on historic buildings refer to:

- Architectural Heritage Protection - Guidelines for Planning Authorities Planning Guidelines No. 9 published by the Department of the Environment, Heritage and Local Government;
- Advice Series: Access – improving the accessibility of historic buildings and places published by the Department of the Environment, Heritage and Local Government.

## 0.9 Fire Safety

Access provision must be linked to provision for emergency egress in the case of a fire. The scope of Part M is limited to matters of access to and use of a building. For guidance on means of escape or evacuation, reference should be made to Technical Guidance Document B (Fire Safety) and the NDA publication 'Promoting Safe Egress and Evacuation of People with Disabilities'.

## 0.10 Diagrams

Diagrams included in this document are intended to clarify certain aspects of the guidance. They are not necessarily to scale and do not represent fully detailed solutions. Where dimensions are stated, they refer to minimum or a range of finished dimensions. Allowance should be made for all necessary tolerances and

finishes and on-site deviation. Reference should be made to Technical Guidance Document D (Materials and Workmanship) for guidance in relation to manufacturing and other tolerances applicable to building components generally.

## 0.11 Disability Act 2005

The Disability Act 2005 aims to advance the participation of people with disabilities in everyday life by, for example, improving access to buildings, services and information. Attention is drawn to the obligation on Public bodies (such as Government Departments, Local Authorities, Health Service Executive, Semi-state Bodies, etc) to make their public buildings comply with Part M 2000, by 2015. It also requires that these public buildings be brought into compliance with amendments to Part M not later than 10 years after the commencement of the amendment. For the purposes of this part of the Disability Act "public building" means a building, or that part of a building, to which members of the public generally have access and which is occupied, managed or controlled by a public body.

The NDA may prepare a draft code of practice relating to the accessibility of public buildings for persons with disabilities, for the purpose of giving guidance to these public bodies, if so requested.

## 0.12 Management

Whilst the provisions of the Building Regulations do not relate to management or maintenance and compliance with the Regulations is not dependent on these, it is acknowledged that they are important functions and contribute to the ongoing accessibility of the building. Key issues

# Access and Use

---

which are generally the responsibility of the management and or maintenance teams include:

- arranging furniture appropriately;
- keeping circulation routes clear, facilities clean, equipment (lifts, communication aids, etc) functioning;
- carrying out maintenance audits on a regular basis;
- conducting staff training and awareness campaigns on peoples specific needs and the use of assistive equipment in buildings e.g. maintenance of induction loops, hoists and other assistive devices;
- putting a detailed emergency action plan in place to ensure safe egress for all in the event of an emergency;
- procurement of accessible goods and services (office furniture, security services, etc);
- providing pre-visit information regarding access to the building on the organisation's website;
- providing information on the accessibility features of the building to occupants, in order to allow for effective management procedures to be put in place.

For guidance on managing buildings refer to Building for Everyone, BS 8300:2009, the NDA publication 'Access Handbook Template' and [www.nda.ie](http://www.nda.ie).

# Section 1

## Access and Use of buildings other than dwellings

---

The guidance in Section 1 applies to buildings other than dwellings and their environs.

The guidance in Section 1 also applies to the common areas of apartment blocks and their environs.

Additional guidance on certain elements and features of existing buildings of the above mentioned types is given in Section 2.

Guidance for dwellings and the common areas of duplex buildings is given in Section 3.

---

# Section 1.1

## Approach to buildings other than dwellings

---

### Section 1.1

#### Approach to buildings other than dwellings

##### 1.1.1 Objective

**The objective is to provide independently accessible means of approach to the accessible entrance(s) of a building and means of circulation around a building.**

##### 1.1.2 Introduction

The approach route(s) to the accessible entrance(s) of a building are the routes from:

- (a) the adjacent road or the entrance point at the boundary of the site, and
- (b) any designated car-parking spaces for people with disabilities and/or setting down areas.

The circulation routes around a building are the routes:

- (c) between the accessible entrance(s) and any other subsidiary entrances and buildings, where external circulation is required between them;
- (d) to and from facilities associated with the building and within the complex; and
- (e) from the building exits to assembly points or to the boundary of the site.

The building should be designed within the overall constraints of space, so that the difference in level between the entrance storey and the site entry point, any designated car-parking spaces, any setting down areas, other subsidiary

entrances/ buildings, any associated facilities or assembly points is minimised. The approach and circulation routes as defined in 1.1.1 should be designed and constructed as access routes in accordance with 1.1.3.

Level access routes accommodate the widest range of abilities and should be provided. For the purpose of this guidance a gradient of 1:50 or less steep is considered to be level. Changes in level are difficult for many people to negotiate (e.g. wheelchair users, people using walking aids, pushing buggies, people with vision impairment) and should be avoided.

Where it is not possible to provide a level access route, a gently sloped access route should be provided. The gradient of a gently sloped approach should be as shallow as possible. For the purpose of this guidance a gradient steeper than 1:50 (but less steep than 1:20) is considered to be gently sloped. Access routes of 1:20 or less steep are preferred.

Where it is not possible to provide a gently sloped access route, a ramped access route should be provided. For the purpose of this guidance a gradient of 1:20 or steeper is considered to be a ramp.

Where the ramp has a rise greater than 300 mm (equivalent to 2 x 150 mm steps), a stepped access route should be provided in addition to a ramped access route. Some people find it easier to use a flight of steps rather than to travel on a ramp e.g. people with mobility difficulties who use certain walking aids; older people, people with vision impairment. Alternatively, a platform lift may be

# Section 1.1

## Approach to buildings other than dwellings

---

provided where site specific constraints require it (in addition to a ramped or stepped access route) conforming to BS 6440:1999<sup>3</sup>.

It is important to restrict the number of barriers, restrictions or other hazards that people encounter on an access route. Guidance on hazard protection is given in 1.1.3.

Where pedestrian crossings are provided along access routes they should be designed and constructed in accordance with the guidance given in 1.1.4.

Where car-parking is provided on site, designated car-parking spaces (exclusively for the use of holders of a disabled person's parking permit) should be provided on a proportional basis. The level of provision, design and construction of designated car-parking spaces should be in accordance with the guidance given in 1.1.5.

Where there is a road on site leading to the building, there should be a setting down area provided at or adjacent to at least one accessible entrance. This facilitates a person arriving at a building as a passenger in a vehicle, to alight from the vehicle and enter the building safely and conveniently. Where setting down areas are provided, they should be designed and constructed in accordance with the guidance given in 1.1.6.

### 1.1.3 Access routes

#### 1.1.3.1 General

The following guidance applies to all access routes, whether level, gently sloped, ramped or stepped. Additional specific guidance on the above four types

of access route is given in 1.1.3.2 to 1.1.3.5.

Where an access route is provided:

- (a) projecting features, which may present hazards, should be avoided to reduce the risks to people with vision impairment. However, if they are unavoidable hazard protection should be provided if objects project more than 100 mm into an access route and their lower front edge is more than 300 mm above the ground. A window or door in general use should not open out onto these routes, within a height of 2100 mm above floor or ground level. Where such hazards are unavoidable, the area should be protected by guarding, planting or other suitable barrier incorporating low level cane detection (refer to Diagrams 1 and 2);
- (b) the minimum headroom provided should be 2100 mm. The underside of stairs, ramps or similar features that restrict headroom below this level should be enclosed. Rationale: This reduces the risk to people especially those with vision impairment from colliding with the edge of these features;
- (c) tapping rails or low level kerbs should be avoided beneath free-standing stairs as they can be a tripping hazard;

---

<sup>3</sup> Platform lifts should comply with the Machinery Directive 2006/42/EC. BS 6400:1999 is partially superseded by EN 81-40. The remainder will eventually be superseded by EN 81-41.

# Section 1.1

## Approach to buildings other than dwellings

- (d) street furniture, such as lighting columns, signposts, litter bins, seats, etc, should be located at or beyond the boundaries of the access route;
- (e) low level posts e.g. bollards should not be located within an access route. Wherever bollards are provided they should contrast visually with their background (refer to 1.6.4) and should be at least 1000 mm high. Bollards should not be linked with chains.  
Rationale: These can be hazardous to people with vision impairment;
- (f) the danger of inadvertently walking into a vehicular route should be minimised by providing a separate pedestrian route. Otherwise, tactile paving should be used to provide warning and guidance for people with vision impairment (refer to 1.1.4);

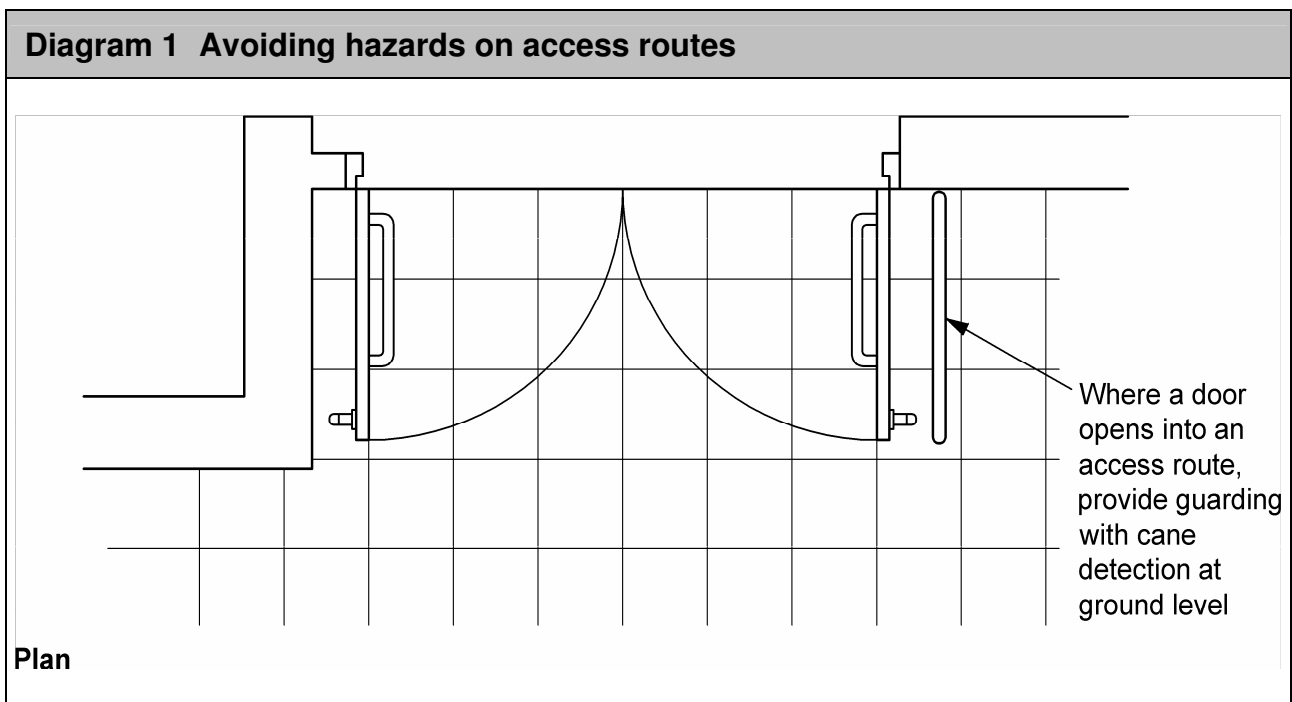

# Section 1.1

## Approach to buildings other than dwellings

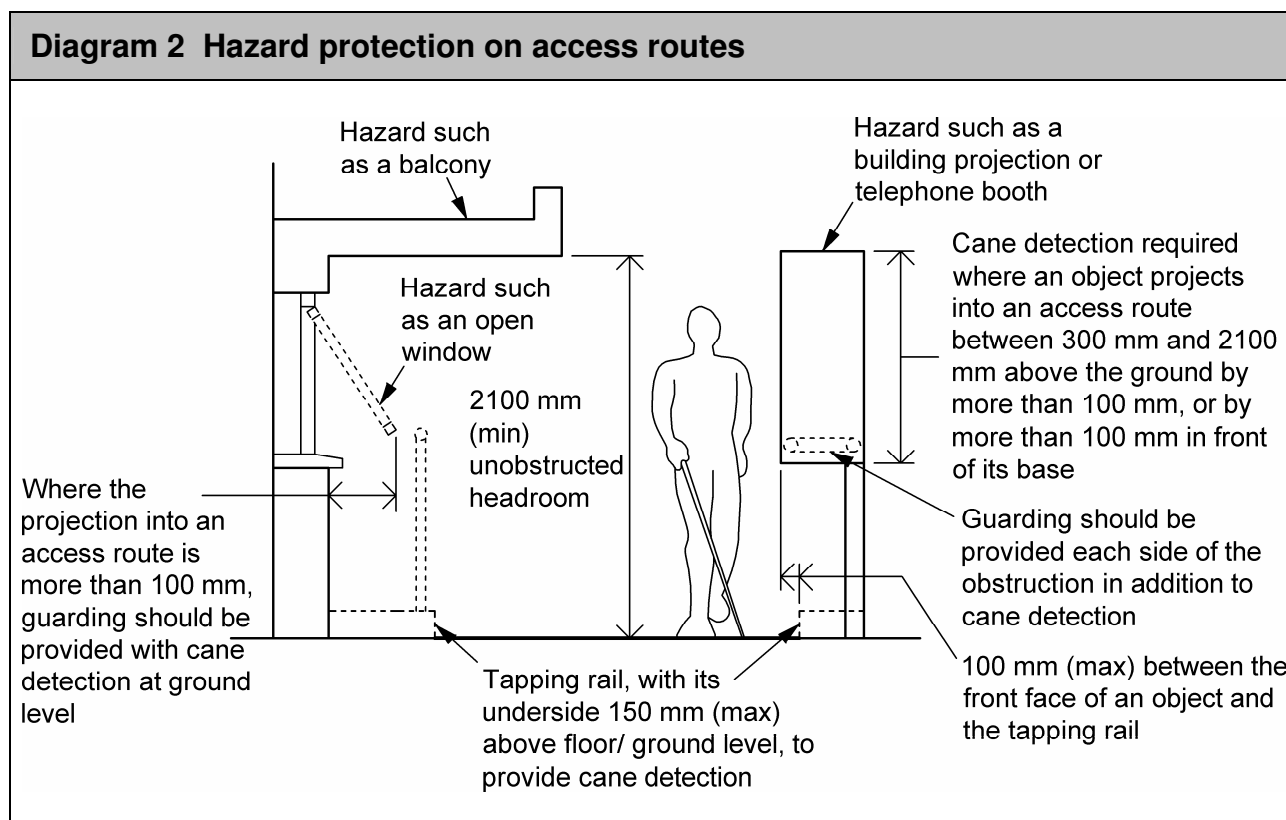

- (g) the access route should be clearly identifiable and well lit. Where this is provided by artificial light it should achieve a minimum luminance of 20 lux on level and gently sloped access routes, with a minimum luminance of 100 lux on ramps or steps, measured at ramp, tread and landing level. Signage should be provided where necessary (refer to 1.6.3);
- (h) drainage gratings should be positioned beyond the boundaries of the access route. Where this is not feasible they should be flush with the surrounding surface.  
Rationale: It is important to minimise the risk of trapping canes or wheelchair wheels;
- (i) dished channels should not be incorporated within an access route  
Rationale: They increase the risk of tripping;
- (j) the surface should be firm, reasonably smooth and durable. Materials such as loose pebbles should not be used;
- (k) the surface should be slip resistant, especially when wet. Guidance on slip resistance is given in BS 8300:2009 Annex E;
- (l) the frictional characteristics of the surface materials used along the access route should be similar to prevent tripping and falling at interfaces between different materials.

# Section 1.1

## Approach to buildings other than dwellings

---

### 1.1.3.2 Level access routes

The following guidance applies to all level access routes **in addition to the general guidance in 1.1.3.1.**

For the purpose of this guidance, a gradient of 1:50 or less steep is considered to be level. Where the gradient of the access route is 1:50 or less steep, it is acceptable for a cross-fall gradient of not steeper than 1:40 to be provided to ensure effective surface drainage.

Where a level access route is provided:

- (a) the minimum clear width (between walls, upstands or kerbs) should be 1500 mm;
- (b) passing places for wheelchair users should be provided. They should be 2000 mm long and 1800 mm wide (inclusive of the width of access route) and located within direct sight of another passing place, or at a maximum spacing of 25 m from each other whichever is closer. Passing places are not required if the access route is a minimum width of 1800 mm.  
Rationale: An 1800 mm wide access route can accommodate non-vehicular traffic without the need for passing places as it allows two wheelchair users to pass one another.

### 1.1.3.3 Gently sloped access routes

The following guidance applies to gently sloped access routes **in addition to the general guidance in 1.1.3.1 above.**

For the purpose of this guidance, a gradient steeper than 1:50 (but less steep

than 1:20) is considered to be gently sloped.

Where a gently sloped access route is provided:

- (a) the minimum clear width (between walls, upstands or kerbs) should be 1500 mm;
- (b) passing places for wheelchair users should be provided. They should be 2000 mm long and 1800 mm wide (inclusive of the width of access route) and located within direct sight of another passing place, or at a maximum spacing of 25 m from another, whichever is closer. Passing places are not required if the access route is a minimum width of 1800 mm or if the access route is less than 25 m long.  
Rationale: An 1800 mm wide access route can accommodate non-vehicular traffic without the need for passing places as it allows two wheelchair users to pass one another;
- (c) where the gradient or part of the gradient is steeper than 1:50 and less steep than 1:20, level landings should be provided at each rise of 500 mm;
- (d) a landing should be provided at the top and bottom of the slope. The top and bottom landings should be at least 1800 mm wide and 1800 mm long and be clear of any door swings or other obstructions;
- (e) intermediate landings should be at least 1500 mm long and clear of any door swings or other obstructions. Intermediate landings should be at



# Section 1.1

## Approach to buildings other than dwellings

---

least 1800 mm wide and 1800 mm long to act as passing places when it is not possible for a wheelchair user to see from one end of the slope to the other or the slope has three flights or more;

- (f) the landings should be level. A level landing is considered to include gradients of 1:50 or less steep.

### 1.1.3.4 Ramped access routes

The following guidance applies to ramped access routes **in addition to the general guidance in 1.1.3.1 above.**

For the purpose of this guidance, a gradient of 1:20 or steeper is considered to be a ramp. Ramped access routes should be designed to have the shallowest gradient practical. The preferred maximum gradient is 1:20 but where site specific constraints require it, ramps not steeper than 1:12 may be provided if individual flights are not longer than 2000 mm.

If the gradient is too steep or an individual flight too long, a person using or pushing a wheelchair may not have sufficient strength to travel up the ramp. There is also the danger of falling forwards going downhill or backwards when going uphill if the gradient is too steep. To ensure adequate control and braking power, the ramp gradients are limited to those in Table 1 and Diagram 3.

Where a ramped access route is provided:

- (a) the minimum clear width (between walls, upstands or kerbs) should be 1500 mm;
- (b) level landings should be provided between ramp flights (as designed in

accordance with Table 1 and Diagram 3) or wherever a change in direction occurs. A level landing is considered to include gradients of 1:50 or less steep;

- (c) a level landing should be provided at the top and bottom of the ramp. The top and bottom landings should be at least 1800 mm long x 1800 mm wide and clear of any door swings or other obstructions;
- (d) intermediate landings should be at least 1500 mm long and clear of any door swings or other obstructions. Intermediate landings should be at least 1800 mm wide and 1800 mm long to act as passing places when it is not possible for a wheelchair user to see from one end of the ramp to the other or the ramp has three flights or more;
- (e) the minimum unobstructed width between handrails should be not less than 1200 mm. Handrails, in accordance with 1.1.3.6 should be provided on both sides. ,  
Rationale: People with restricted mobility may be weaker on one side and therefore a handrail on each side of the flight is essential for support when ascending and descending ramps;
- (f) edge protection in the form of a 100 mm high (minimum) upstand should be provided on the open side of any ramp or landing. It should contrast visually with the surface of the ramp and landing (refer to 1.6.4). Reference should be made to Part K/ TGD K where additional guarding may be required in some circumstances;

## Section 1.1

### Approach to buildings other than dwellings

---

- (g) the ramped access route may form part of a wider ramped area. The intended ramped access route(s) should be clearly identified and signposted where necessary (refer to 1.6.3). Additional handrails should be used to divide any intended ramped access route into channels of unobstructed width not less than 1200 mm and not greater than 2500 mm.  
Rationale: This permits a person with less strength on one side to be within easy reach of support;
- (h) a stepped access route should be provided in addition to a ramped access route where the rise of the ramp is greater than 300 mm (equivalent to 2 x 150 mm steps).  
Rationale: Some people find it easier to use a flight of steps rather than to travel on a ramp e.g. people with mobility difficulties who use certain walking-aids, older people, people with vision impairment;
- (i) an alternative means of access for wheelchair users should be provided e.g. a platform lift, where the ramp is 1:20 or greater and the total rise of the ramp is greater than 2000 mm. A platform lift should conform to BS 6440:1999<sup>3</sup>.  
Rationale: Ramps simply become too tiring for wheelchair users beyond this height.

---

<sup>3</sup> Platform lifts should comply with the Machinery Directive 2006/42/EC. BS 6400:1999 is partially superseded by EN 81-40:2008. The remainder will eventually be superseded by EN 81-41.

# Section 1.1

## Approach to buildings other than dwellings

**Table 1 Limits for ramp gradients and lengths**

Maximum going of a flight	Maximum gradient	Maximum rise
Not exceeding 10 m	1:20	500 mm
Not exceeding 5 m	1:15	333 mm
Not exceeding 2 m	1:12	166 mm

**NOTE:** For goings between 2 m and 10 m, it is acceptable to interpolate between the maximum gradients (refer to Diagram 3).

**Diagram 3 Relationship between ramp gradient and the maximum going of a flight**

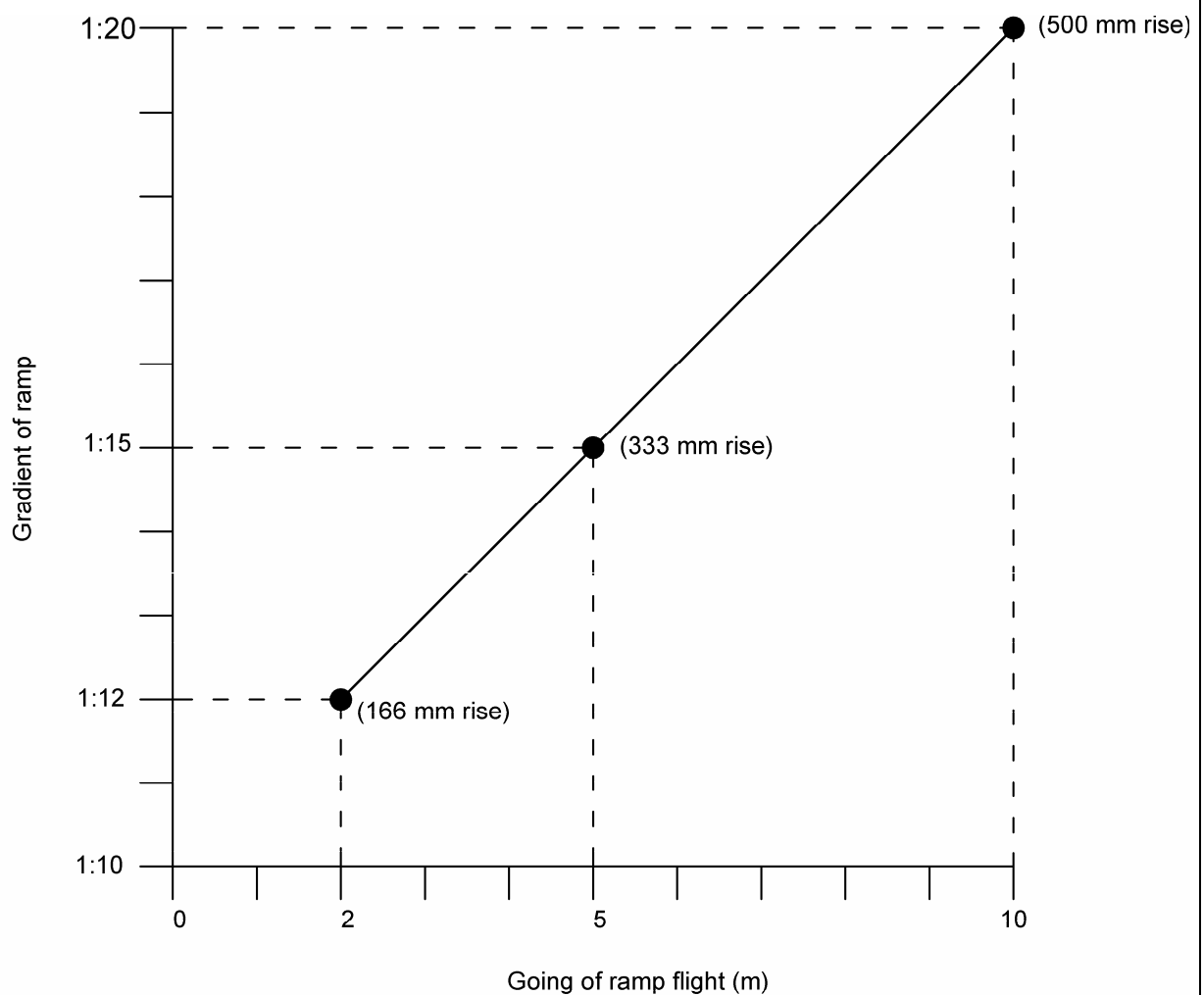

**NOTE:** Where space permits, the gentlest possible gradient should be chosen i.e. the shallowest possible gradient between 1:12 and 1:20

# Section 1.1

## Approach to buildings other than dwellings

---

### 1.1.3.5 Stepped access routes

Functional requirements and guidance on compliance, for stairs are given in various Parts of the Building Regulations namely Part B for escape, Part K for stairs in general and Part M for stairs suitable for ambulant disabled people. Designers should be aware of the function of the stairs they are designing and refer to the appropriate Part and accompanying TGD. The following guidance applies to all stepped access routes **in addition to the general guidance in 1.1.3.1.**

Where a stepped access route is provided:

- (a) the minimum clear width (between enclosing walls, strings or upstands) should be 1200 mm;
  - (b) a landing should be provided at the top and bottom of each flight;
  - (c) the landings should be level and have an unobstructed length (clear of any door or gate swing) of at least 1200 mm;
  - (d) tactile hazard warning surfaces should be incorporated at both the top and bottom landings. A corduroy tactile warning surface should be provided in accordance with Diagrams 4a and 4b.  
Rationale: People with vision impairment risk tripping or losing their balance if there is no warning that steps provide a change in level. The greatest risk lies at the top of a flight of stairs when a person is descending;
  - (e) an intermediate landing with side access should have a tactile hazard warning surface 400 mm deep on the landing 400 mm from both upper and lower flights (if there is sufficient space to accommodate the surface outside the line of the side access). Where space is insufficient to accommodate the above, a tactile warning surface 400 mm deep should be provided, within the side access 400 mm from the intermediate landing so long as there is a continuous handrail opposite the side access;
- (f) there should be no single steps;
  - (g) the rise of a flight between landings should not exceed 1500 mm. However a single flight containing 18 risers or less is acceptable if the going is 350 mm or greater.  
Rationale: A greater going allows people with mobility difficulties or vision impairment to place their feet square on a step. It also allows a person to stand and rest at any point within a flight and thus the flight can be extended to greater heights;
  - (h) all step nosings should incorporate a permanently contrasting continuous material on the tread. The material should be between 50 mm and 65 mm wide on the tread and should contrast visually with the remainder of the tread (refer to 1.6.4).  
Rationale: This will help people with vision impairment appreciate the extent of the stair and identify the individual treads;
  - (i) projecting or overhanging step nosings should be avoided  
Rationale: Projecting step nosings can cause people to trip or catch their feet. Refer to Diagram 5 for acceptable tread and riser profiles;

## Section 1.1

### Approach to buildings other than dwellings

---

- (j) the rise and going of each step should be consistent throughout a flight;  
Rationale: This permits a person with less strength on one side to be within easy reach of support;
- (k) the rise of each step should be between 150 mm and 180 mm.  
Rationale: Excessively high risers may result in strain being placed on knee and/or hip joints when descending and should thus be avoided;
- (l) the going of each step should be between 300 mm and 450 mm.  
Rationale: For people with mobility difficulties, a going of at least 300 mm is preferred. A larger going helps avoid accidents on a stair particularly on descent, as it allows a person to place more of their foot on the step;
- (m) tapered treads and open risers should not be used.  
Rationale: They create a sense of insecurity for people with vision impairment;
- (n) there should be a continuous handrail on each side of flights and landings in accordance with 1.1.3.6. The minimum unobstructed width between handrails should be not less than 1000 mm. ;
- (o) the stepped access route may form part of a wider stepped area. The intended stepped access route(s) should be clearly identified and signposted where necessary (refer to 1.6.3). Additional handrails should be used to divide any intended stepped access route into channels of unobstructed width not less than 1000 mm and not greater than 2000 mm.
- (p) the surface of the treads should be slip resistant, especially when wet. Guidance on slip resistance is given in BS 8300:2009 Annex E.

# Section 1.1

## Approach to buildings other than dwellings

**Diagram 4a Stepped Access – Key dimensions and use of hazard warning surface**

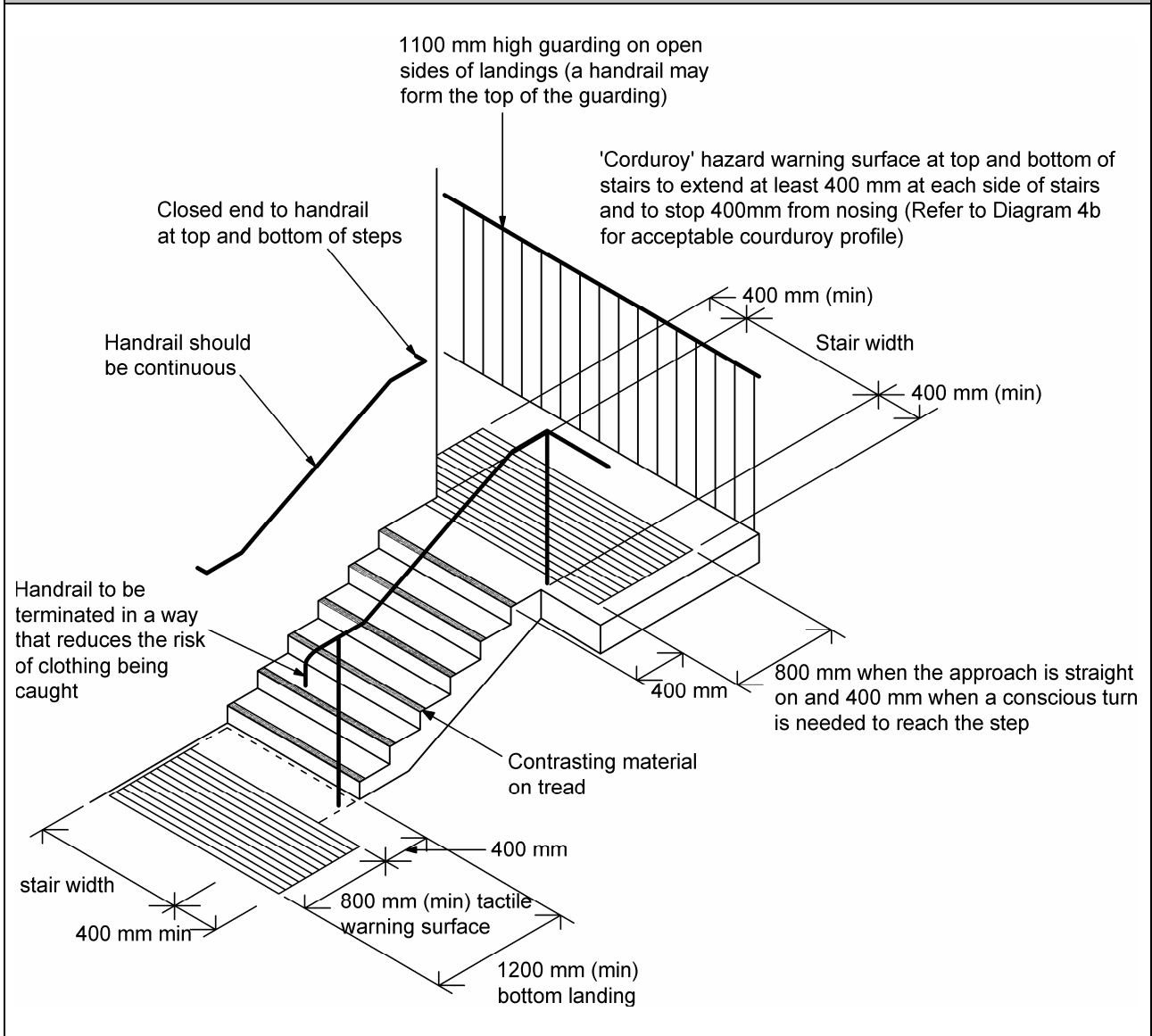

# Section 1.1

## Approach to buildings other than dwellings

**Diagram 4b Corduroy profile (for use with stepped access only)**

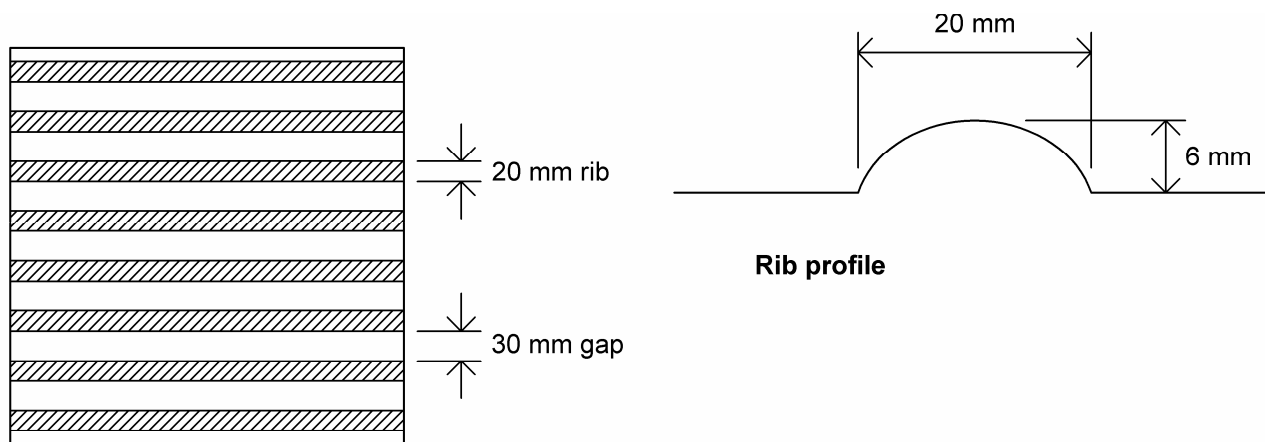

**'Corduroy' hazard warning surface (with 8 ribs)**

**NOTE:** Full details on the use of tactile paving are in 'Good Practice Guidelines on Accessibility of Streetscapes'

# Section 1.1

## Approach to buildings other than dwellings

**Diagram 5** Examples of step profiles and key dimensions for stepped access routes

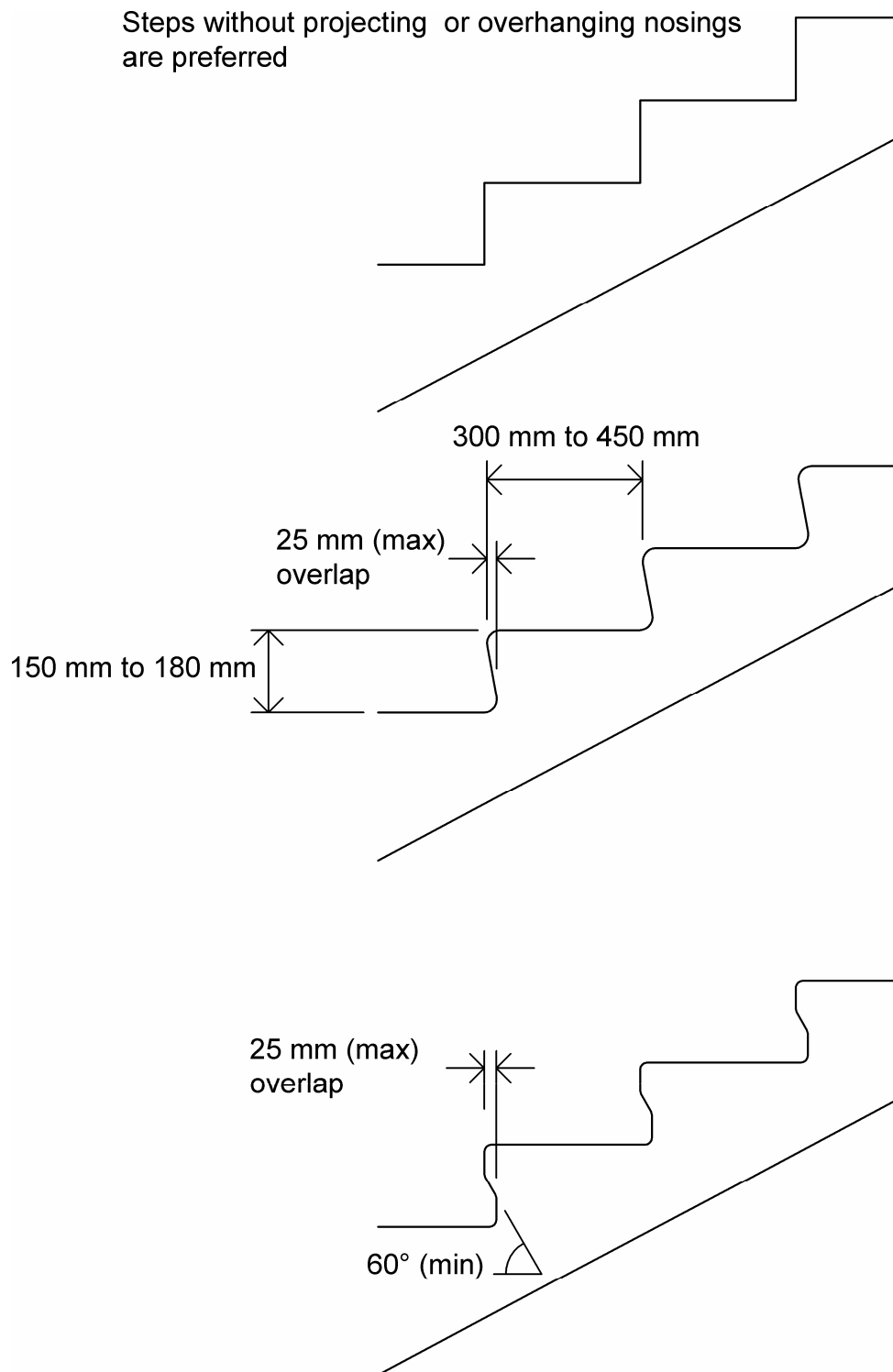

**NOTE:** Rise and going dimensions apply to all step profiles



# Section 1.1

## Approach to buildings other than dwellings

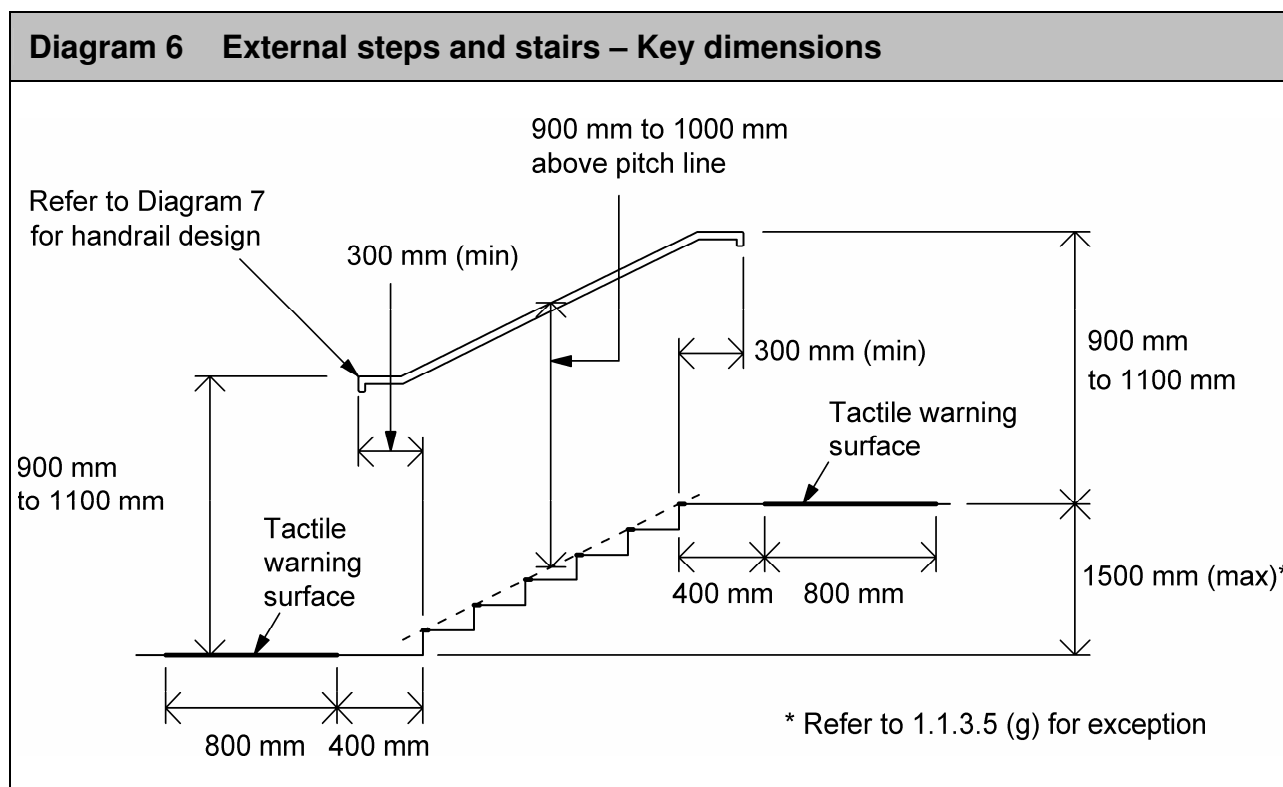

### 1.1.3.6 Handrails

General guidance on handrails and guarding is given in TGD K, but the guidance that follows applies to handrails on accessible access routes.

Where handrails are provided on a ramped or stepped access route:

- (a) the vertical height to the top of the upper handrail from the pitch line of the surface of a flight should be between 900 mm and 1000 mm and from the surface of a landing should be between 900 mm and 1100 mm (refer to Diagram 6). Where a second handrail on stairs is provided for children or those of short stature the vertical height to the top of a second lower handrail from the pitch line of the surface of a flight should be between 600 mm and 700 mm;
- (b) where there are two or more flights separated by a landing or landings, the handrails should be continuous across flights and landings, except where broken by side access routes on landings;
- (c) where the handrail is not continuous the handrail should extend at least 300 mm beyond the top and bottom of a ramped approach and the top and bottom risers of a stepped approach, and terminate in a closed end which does not project into a route of travel. Handrails should be terminated in such a way that reduces the risk of clothing being caught;
- (d) the background against which the handrails are seen should contrast visually without being highly reflective (refer to 1.6.4);

## Section 1.1

### Approach to buildings other than dwellings

---

- (e) the profile should be either circular with diameter of between 40 mm to 50 mm or oval with a width of 50 mm (refer to Diagram 7);
- (f) handrails should not protrude more than 100 mm into the surface width of the access route where this would impinge on the stair width requirement of TGD B – Methods of Measurement;
- (g) there should be a clearance of at least 50 mm to 60 mm between the handrail and any adjacent wall surface (refer to Diagram 7);
- (h) there should be a clearance of at least 50 mm between a cranked support and the underside of the handrail (refer to Diagram 7). The handrail support should meet the handrail centrally on its underside  
Rationale: This will minimise the risk of the handrail supports interrupting the smooth running of a person's hand along the rail;
- (i) the handrails inner face should be located no more than 50 mm beyond the surface width of the access route (refer to Diagram 7);
- (j) handrail fixings should be designed to meet the loading recommendations of I.S. EN 1991-1-1:2002.

# Section 1.1

## Approach to buildings other than dwellings

**Diagram 7 Handrail design**

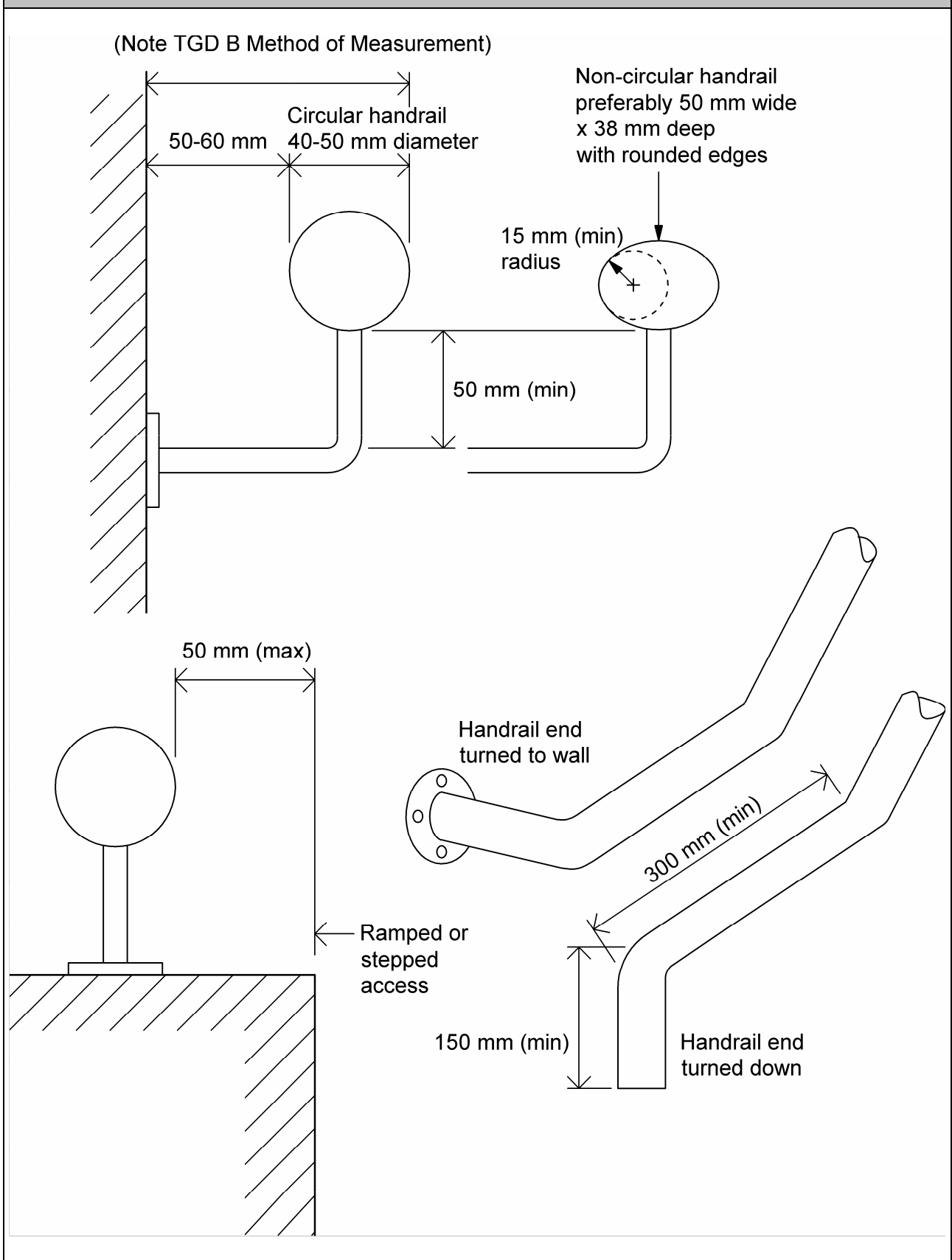

# Section 1.1

## Approach to buildings other than dwellings

---

### 1.1.4 Pedestrian crossings

Where pedestrian crossings are provided, tactile paving and dropped kerbs should be provided at controlled and uncontrolled pedestrian crossings in accordance with 'Good Practice Guidelines on Accessibility of Streetscapes'.

### 1.1.5 On-site car parking

For the purposes of this section, designated car parking spaces are those spaces exclusively provided for the holders of a disabled person's parking permit.

Where on-site car parking is provided, whether for residents, employees, visitors or others, a number of designated car parking spaces should be provided, on a proportional basis.

In the absence of a specific number of designated spaces being required by a Local Authority through Development Plans or as a condition of planning, the following guidance applies.

For buildings (including apartment buildings), at least 5% of the total number of spaces should be designated car parking spaces, with a minimum provision of at least one such space.

Further guidance on the provision of designated car parking spaces is given in BS 8300:2009 and Sustainable Urban Housing: Design Standards for New Apartments - Guidelines for Planning Authorities.

Where designated parking is provided either outside or within a building:

(a) it should be easily located. If necessary signage should be

provided, (refer to 1.6.3), at the entrance to each car park and at each change in direction to direct motorists to designated spaces;

(b) ticketing machines, access routes to buildings or other services such as lifts, etc; should be easily located. Clear signage should be provided, where necessary, to direct people (refer to 1.6.3);

(c) it should be possible for all motorists to activate car park control barriers. Ticket, swipe card or key activated controls can be difficult to reach and manipulate by some drivers (Refer to BS 8300:2009 for further guidance). Barrier control systems should conform to BS 6571- 4:1989;

(d) the minimum dimensions of the designated parking bays should be in accordance with Diagrams 8 and 9;

(e) A 1200 mm wide access zone should be provided on both sides and at the rear of each designated parking bay. The access zone at the rear of the parking bay should be clear of vehicular circulation routes. The access zone should contrast visually with the adjoining surfaces to ensure it is kept clear (refer to 1.6.4).

Rationale: This provides sufficient space to enter and leave the vehicle and move to the rear of the vehicle and should safely lead to an access route;

(f) a minimum clear vertical clearance of 2600 mm (on level ground) should be provided to allow the passage of high top conversion vehicles. This

## Section 1.1

### Approach to buildings other than dwellings

---

should be maintained along the route to and from the designated car parking bays from the site boundary. Alternatively, drivers should be warned about the height restrictions and directed to alternative parking spaces or a setting down area suitable to accommodate high top conversion vehicles;

machine to allow adequate space for a wheelchair user to approach, manoeuvre side on to the machine, turn and return to the vehicle. For further guidance on the accessibility of ticket machines refer to the NDA publication 'Guidelines for Public Access Terminals'.

- (g) all designated parking bays should be clearly marked on the ground with the symbol of access and, if necessary further signage should be provided (refer to 1.6.3);
- (h) the designated parking bay should be on firm, level<sup>4</sup> ground and be the parking bay(s) located closest to the accessible entrance(s) with which the provision of parking spaces is associated;
- (i) the surface of the access zone should be firm, level<sup>4</sup>, durable, reasonably smooth and slip resistant. Materials such as loose pebbles should not be used;
- (j) dropped kerbs should be provided in accordance with 1.1.4 to facilitate easy transfer from the designated parking bay(s) to the access routes without undue effort or barrier;
- (k) ticket machines, where used, should be situated adjacent to the designated parking bays and at least one machine should have controls between 750 mm and 1200 mm above ground. The supporting plinth should not project in front of the face of the machine in a way that prevents its convenient use. There should be a clear space of 1850 mm deep x 2100 mm long in front of the

---

<sup>4</sup> For the purpose of this guidance, a gradient of 1:50 or less steep is considered to be level. Where the gradient is 1:50 or less steep, it is acceptable for a cross-fall gradient of not steeper than 1:40 to be provided to ensure effective surface drainage.

# Section 1.1

## Approach to buildings other than dwellings

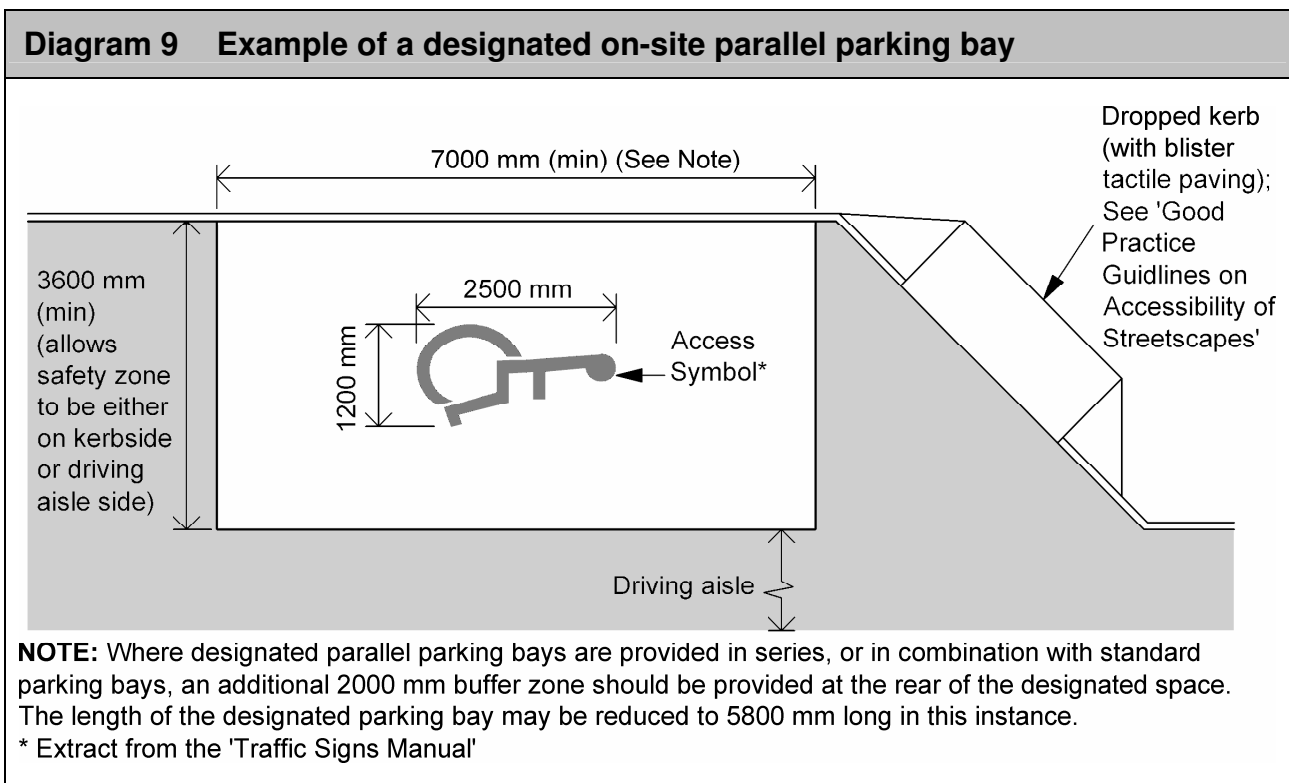
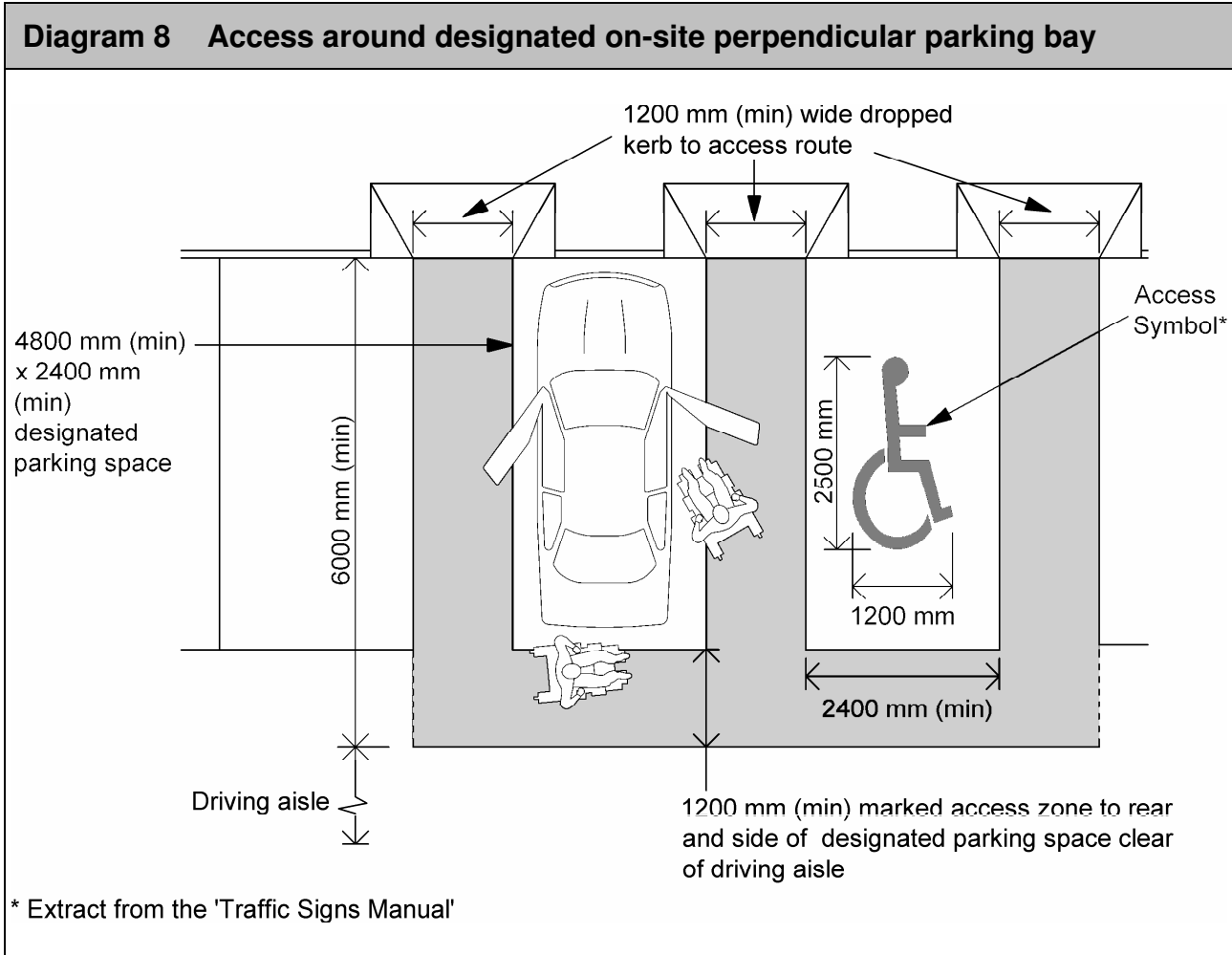

# Section 1.1

## Approach to buildings other than dwellings

---

### 1.1.6 On-site setting down areas

Where there is a road on site leading to the building, there should be a setting down area provided at, or adjacent to, at least, one accessible entrance. This facilitates a person arriving at a building as a passenger in a vehicle, to alight from the vehicle and enter the building safely and conveniently.

Where a setting down area is provided:

- (a) it should be easily located. If necessary signage should be provided, (refer to 1.6.3);
- (b) it should be located on firm and level<sup>4</sup> ground as close as practicable to the accessible entrance(s) and should not form an obstruction to through traffic;
- (c) an access route in accordance with 1.1.3 should lead from the setting down area to an accessible entrance;
- (d) the surface of the access route alongside the setting down area should be level<sup>4</sup> with the carriageway at that point to facilitate wheelchair users. Otherwise dropped kerbs should be provided.

---

<sup>4</sup> For the purpose of this guidance, a gradient of 1:50 or less steep is considered to be level. Where the gradient is 1:50 or less steep, it is acceptable for a cross-fall gradient of not steeper than 1:40 to be provided to ensure effective surface drainage.

# Section 1.2

## Access to buildings other than dwellings

---

### Section 1.2

#### Access to buildings other than dwellings

##### 1.2.1 Objective

**The objective is to provide entrances to buildings that are independently accessible and to avoid segregation based on a person's level of ability.**

##### 1.2.2 Introduction

All of the following entrances should be accessible:

- (a) the main entrance which a visitor not familiar with the building would normally expect to approach;
- (b) the entrance closest to the designated parking area, and
- (c) the entrance closest to the setting down area.

Subsidiary external entrances that should also be accessible include:

- (d) any main entrance to a unique functional area or facility of a building e.g. in multi-occupancy buildings (retail, office, residential areas, etc), or multi-functional buildings (hospitals with separate entrances for reception, A&E, outpatients, etc);
- (e) any entrance used exclusively by staff, and
- (f) building exits to assembly points or to the boundary of the site.

Where main entrances are accessible to all they promote a spirit of inclusion that segregated accessible entrances do not. In certain exceptional situations it may not

be practicable for each of the entrance(s) above to be accessible, due to steeply sloped or restricted sites or planning requirements. Therefore, in such circumstances only, an alternative accessible entrance or entrances may be provided.

##### 1.2.3 Accessible entrances

Accessible entrances should facilitate the widest possible range of abilities.

Approaches to accessible entrances should comply with Section 1.1.

The route from an alternative accessible entrance should lead directly, via an accessible internal route conforming to Section 1.3, to the spaces served by the corresponding main entrances.

Likewise, entrances close to the designated parking area and setting down area, (b) and (c) above, should connect to the main entrance reception area (or equivalent), via an accessible internal route conforming to Section 1.3.

Main entrances and subsidiary entrances should be clearly identifiable. Signage should be provided where necessary (refer to 1.6.3).

Where an accessible entrance is provided:

- (a) it should be easily identified among the other elements of the building under all lighting conditions, shadow or strong sunlight e.g. by lighting and/or visual contrast (refer to 1.6.4). Glare and reflection from lighting or materials should be avoided as it is confusing for those with vision impairment (refer to 1.6.5);



## Section 1.2

### Access to buildings other than dwellings

---

- (b) a level landing at least 1800 mm x 1800 mm clear of any door or gate swing should be provided immediately in front of the entrance;
- (c) the surface of the landing should not impede the movement of wheelchairs or other mobility aids;
- (d) the threshold should be level, i.e. with a maximum threshold height of 15 mm with exposed edges chamfered or pencil rounded.  
Rationale: Level thresholds do not create a trip hazard or barrier to people using wheelchairs or other mobility aids;
- (e) any door entry system should be accessible to people with a wide range of abilities. Particular attention should be paid to the needs of people with hearing, vision, speech or mobility impairment including wheelchair users. Refer to the NDA publication 'Guidelines for Public Access Terminals Accessibility';
- (f) any structural supports at the entrance should not present a hazard for people with vision impairment;
- (g) internal floor surfaces adjacent to the threshold should not impede the movement of wheelchairs or other mobility aids;
- (h) changes in floor materials adjacent to threshold should not create a potential trip hazard, and
- (i) where mat wells are provided, the surface of the mat should be level with the surface of the adjacent floor

finish and the material should be firm.

Rationale: This will prevent wheels from sinking into the surface which causes difficulty for a person using a wheelchair or mobility aid to manoeuvre.

#### 1.2.4 Accessible entrance doors

Manually operated external doors, with a self-closing device, can pose difficulties for people with a wide range of abilities, including children. It is extremely difficult for people with limited upper body strength, with assistance dogs, walking aids or wheelchairs, to open and manoeuvre through this type of door as it requires an opening force greater than the resistance force of the self-closing device itself plus any extra resistance exerted by weather seals and/or wind pressure. This may result in people being unable to continue their journey independently.

If the force required for opening doors is too great or its speed of closing is too fast, people with disabilities risk being pushed off balance. Any self-closing hinged (single swing) or pivoted (single or double swing) entrance doors should have controlled closing devices and allow independent use by people with disabilities. Guidance is given in 1.2.4.2 on accessible manual doors.

Where it is not possible for a controlled closing device to close an entrance door and keep it closed against external conditions without exceeding the opening force set out in 1.2.4.2 (a), one of the following should be used:

- (i) a power-operated door – sliding, folding, balanced or swing (refer to 1.2.4.3);

## Section 1.2

### Access to buildings other than dwellings

---

(ii) a low energy swing door (refer to 1.2.4.4);

(iii) a lobby or air lock system of inner and outer doors (refer to 1.2.5).

Powered door opening and closing systems are accessible to a very wide range of people as they require little, if any, strength to open. Powered sliding doors, either manually controlled or automatically operated by sensors, are the preferred type of accessible entrance door.

In general, revolving doors are not considered accessible and present particular difficulties and risk injury for people with vision impairment, assistance dogs, mobility difficulties, elderly people and for parents with small children or buggies. Where a revolving door is used, a complementary accessible door should be provided immediately adjacent to the revolving door and be available for use at all times. The accessible door may be a swing, sliding or folding door, and be automatic, manual or power-operated and should be clearly identifiable.

Doors that provide high levels of accessibility may not always be suitable as escape doors. Where an accessible entrance door also forms part of an escape route reference should be made to the guidance in TGD B (refer to section dealing with General Provisions for Means of Escape), on doors across escape routes, including automatic doors, to ensure compliance with Part B.

Where an accessible entrance door is provided:

(a) it should have an effective clear width (refer to Diagram 10) through a single door or at least one leaf of a double door as set out in Table 2 below;

(b) door handles should be located at a height of between 800 mm and 1050 mm (900 mm preferred) above finished floor level. Where a pull handle is provided the available grip zone of the pull handle should be between 700 mm (min) to 1000 mm (max) above finished floor level. The top end of the pull handle should be 1300 mm (min) above floor level;

(c) where possible, unless for reasons of security, entrance and lobby door leaves and side panels wider than 450 mm should have vision panels towards the leading edge of the door. The minimum vertical zone of visibility should be between 500 mm and 1500 mm from the floor. If a door has multiple viewing panels, the minimum zone of visibility should not be interrupted by opaque areas that obstruct more than 350 mm of the vertical height of the zone. Rationale: This allows people to see another person approaching the door in the other direction in time to avoid a collision. The extent of the visibility zone facilitates people of all heights or those using a wheelchair. Refer to Diagram 10 for more details;

(d) it can be a manual or power-operated door in accordance with 1.2.4.1 to 1.2.4.4 respectively.

## Section 1.2

### Access to buildings other than dwellings

---

<b>Table 2 Minimum effective clear widths of doors</b>	
<b>Direction and width of approach</b>	<b>Minimum effective clear width<sup>(a)</sup></b>
Straight on (without a turn or oblique approach)	800 mm
At right angles to an access route at least 1500 mm wide	800 mm
At right angles to an access route at least 1200 mm wide	825 mm
External doors and internal lobby doors at the entrance of buildings used by the general public <sup>(b)</sup>	1000 mm

**NOTES:**

(a) The effective clear width should be measured in accordance with Diagram 10.

(b) Buildings used by the general public include day centres, hotels, institutional buildings, places of assembly, shops, shopping centres and office buildings with a nett floor area<sup>(c)</sup> per floor greater than 200 m<sup>2</sup>. (Refer to Page 13 for definitions)

(c) When calculating the nett floor area of any storey, the area provided for vertical circulation, common sanitary facilities and maintenance areas in the storey should not be included.

# Section 1.2

## Access to buildings other than dwellings

**Diagram 10 Effective clear width and visibility requirements of doors**

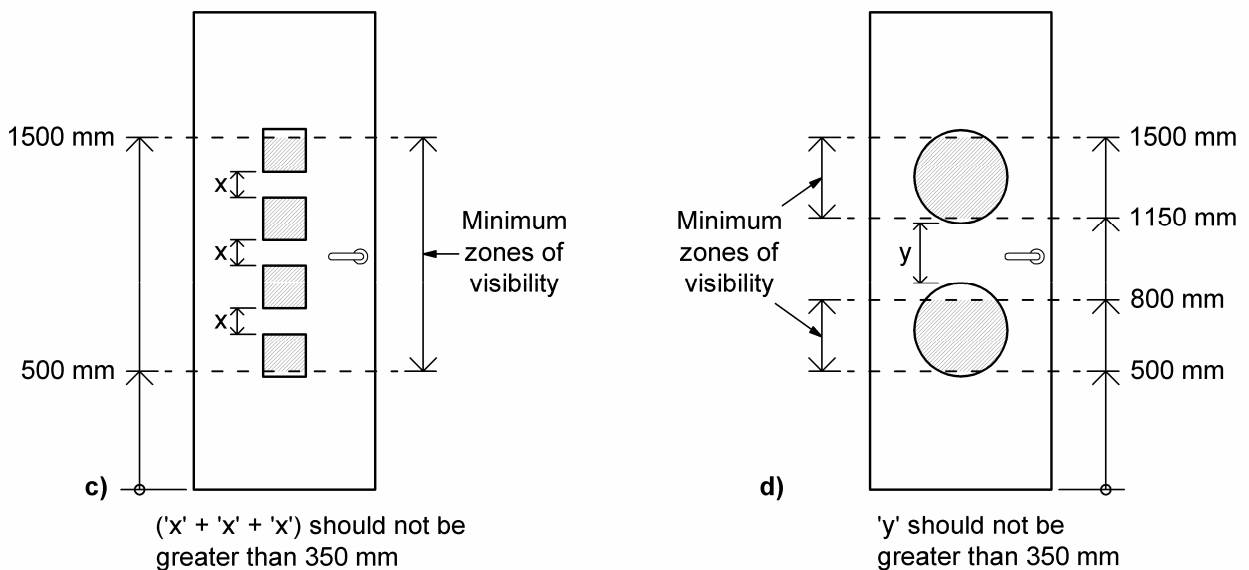
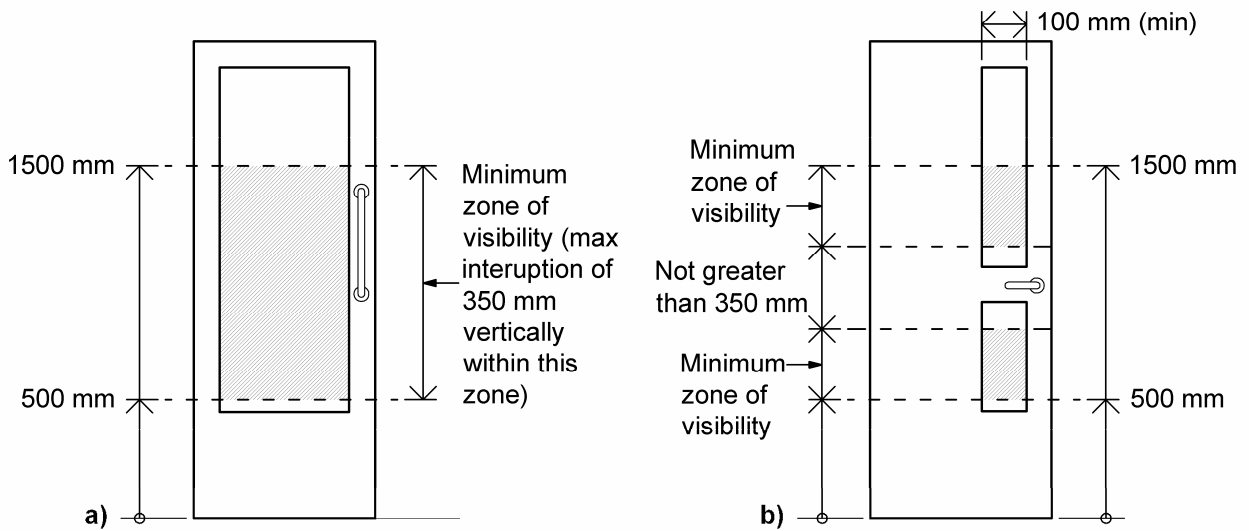
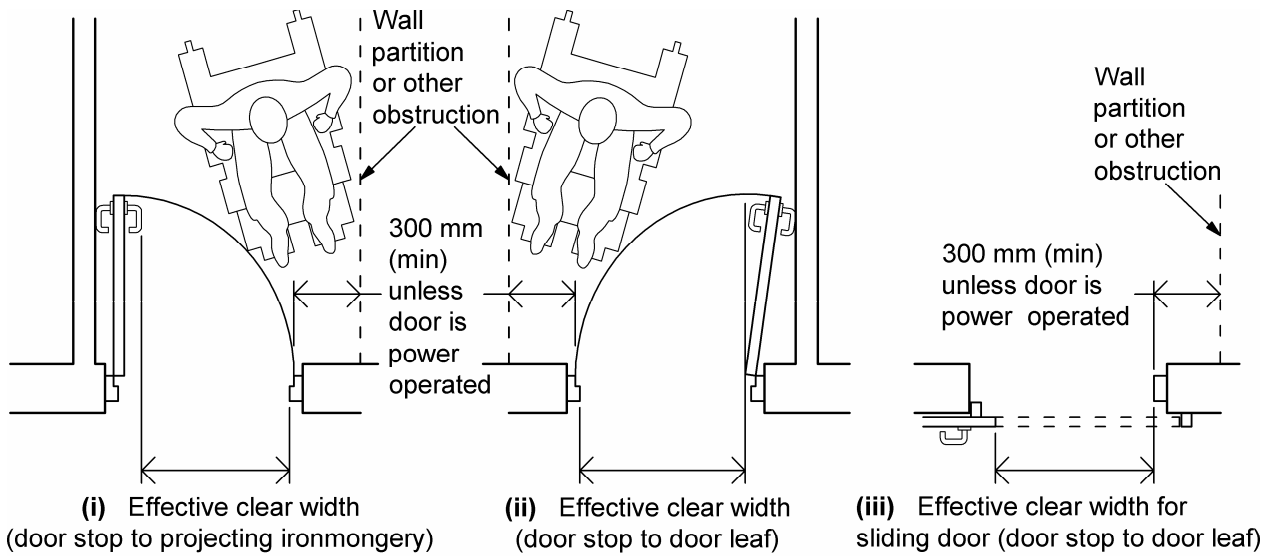

## Section 1.2

### Access to buildings other than dwellings

---

#### 1.2.4.1 Accessible glass doors

Where the external door leaves (including lobby doors) consist of a frameless glass door or a fully glazed framed door with a narrow stile the following guidance applies **in addition to the general guidance in 1.2.4 above.**

Where accessible glass doors are provided:

- (a) the door should be clearly defined with permanent manifestation on the glass, within two zones, from 850 mm to 1000 mm and from 1400 mm to 1600 mm above the floor, contrasting visually with the background seen through the glass (from inside and outside) in all lighting conditions (refer to 1.6.5). The edges of a glass door should also be apparent when the door is open (refer to 1.6.4) ;
- (b) if the manifestation takes the form of a logo or sign, it should be at least 150 mm high (repeated if on a glazed screen) or at least 50 mm high if it takes the form of a decorative feature such as broken lines or continuous bands;
- (c) if a glass door is adjacent to, or is incorporated within, a fully glazed wall or glazed screen, the door and wall or screen should be clearly differentiated from one another, with the door being more prominent e.g. the door may be framed on both sides and on the top by an opaque high-contrast strip at least 25 mm wide.  
Rationale: This ensures that people with vision impairment can clearly identify the location of the door;

- (d) the door, where it is capable of being held open, should be protected by guarding to prevent the leading edge constituting a hazard. Further guidance on the design of glazed doors is given in BS 6262:2005.

#### 1.2.4.2 Accessible manual doors

The following guidance applies to accessible manual doors **in addition to the general guidance in 1.2.4 above.**

Where accessible manual doors are provided:

- (a) when measured from the leading edge of the door, the opening force should be not more than 30N from 0° (the door in the closed position) to 30° open, and not more than 22.5N from 30° to 60°degrees of the opening cycle<sup>5</sup>;
- (b) there should be an unobstructed space of at least 300 mm between the leading edge of a single leaf door (when it opens towards you) and a return wall, unless the door is opened by remote automatic control  
Rationale: This enables a person in a wheelchair to reach and grip the door handle, then open the door without releasing hold on the handle and without the footrest colliding with the return wall (refer to Diagram 10);

---

<sup>5</sup> The accuracy of force measuring instruments available on the market varies. There are also inherent difficulties in measuring forces on site. It is recognised, therefore, that any measurements will be subject to a degree of imprecision which could give rise to variations of between 2 and 3 N.

## Section 1.2

### Access to buildings other than dwellings

---

- (c) where fitted with a latch, the door opening furniture should be operable with one hand, without the need to grab and twist (i.e. using a closed fist) e.g. a lever handle.

Rationale: This facilitates people with limited manual dexterity;

- (d) all door opening furniture should contrast visually with the surface of the door to assist those with vision impairment (refer to 1.6.4).

#### 1.2.4.3 Accessible power-operated doors

The provision of power-operated doors should be in accordance with BS 7036-1:1996. The following guidance applies to accessible power-operated doors **in addition to the general guidance in 1.2.4 above.**

Accessible power-operated doors may have a sliding, swinging or folding action controlled by one of the following two types:

- (i) Manually by a push pad, coded entry or remote control, or
- (ii) Automatically by a motion sensor or other proximity sensor, e.g. a contact mat or hands-free proximity sensor.

Where an accessible power-operated door is provided:

- (a) when installed, automatic sensors should be set so that automatically operated doors open early enough and stay open long enough to maintain safe entry and exit. The activation device(s) should be positioned to detect traffic at a

suitable distance, taking account of the width, mass and operating speed of the door. Detection by presence and motion sensing devices should be incorporated into all power-operated door installations. Refer to BS 7036-1:1996;

- (b) manual activation controls should be located between 750 mm and 1000 mm above the finished floor level and be operable with a closed fist;

- (c) manual activation controls should contrast visually with the surrounding background so they are readily distinguishable by people with vision impairment (refer to 1.6.4);

- (d) doors that have a swinging action and open towards the approach should be provided with clearly visible warning signs to warn people of their automatic operation when both opening and closing. Audible warning systems are not recommended due to the possibility of confusion about the direction of opening and direction of approach;

- (e) control systems should incorporate a safety stop that activates if the door(s) begin to close when a person is passing through;

- (f) control systems should revert to manual control or fail safe in the open position in the event of a power failure;

- (g) doors should not project into any adjacent access route when open. If this is unavoidable hazard protection

## Section 1.2

### Access to buildings other than dwellings

---

should be provided in accordance with 1.1.3.1(a) and Diagram 1.

#### 1.2.4.4 Low energy swing doors

A low energy power-operated door operator may be used on swing doors with relatively low levels of pedestrian usage as these doors can either work in manual mode or be set to provide powered opening assistance to users when required, either in push-and-go or power-assisted mode. The push-and-go power assist should activate when the door is pushed beyond 25 mm. If low energy swing doors are used, safety provisions for the doors should conform to BS 7036-4:1996.

#### 1.2.5 Entrance lobbies

Entrance lobbies serve a number of functions including air infiltration and draught reduction. The presence of an entrance lobby may allow the external door to have a lower powered self-closing device. Where they are provided they should be designed and constructed to ensure that there is sufficient space to enable a person using a wheelchair and an assistant to move clear of one door before opening the other door.

Where an accessible entrance lobby is provided:

- (a) the length should be in accordance with Diagram 11 for single swing doors and at least  $DP1 + DP2 + 1570$  mm for double swing doors;
- (b) the width (excluding any projections into the space) should be (Greater of  $DL1$  or  $DL2$ ) + 300 mm, when single leaf doors are used and at least 1800 mm when double leaf doors are used;

- (c) areas of full height glazing, glazed curtain walling or glazed screens surrounding a lobby should display the manifestations as required for glass doors in 1.2.4.1;
- (d) floor surface materials within the lobby should not impede the movement of wheelchairs or other mobility aids;
- (e) changes in floor materials should not create a potential trip hazard;
- (f) any columns, ducts or similar full height elements that project into the lobby by more than 100 mm should be protected by a visually contrasting guard rail (refer to 1.6.4);
- (g) the floor surface should help remove rainwater from shoes and wheelchairs.  
Rationale: This reduces the potential for slipping within the building e.g. by using cleaning mats;
- (h) where mat wells are provided, the surface of the mat should be level with the surface of the adjacent floor finish and the material should be firm.  
Rationale: This will prevent wheels from sinking into the surface which causes difficulty for a person using a wheelchair or mobility aid to manoeuvre.

# Section 1.2

## Access to buildings other than dwellings

**Diagram 11 Key dimensions for lobbies with single leaf doors**

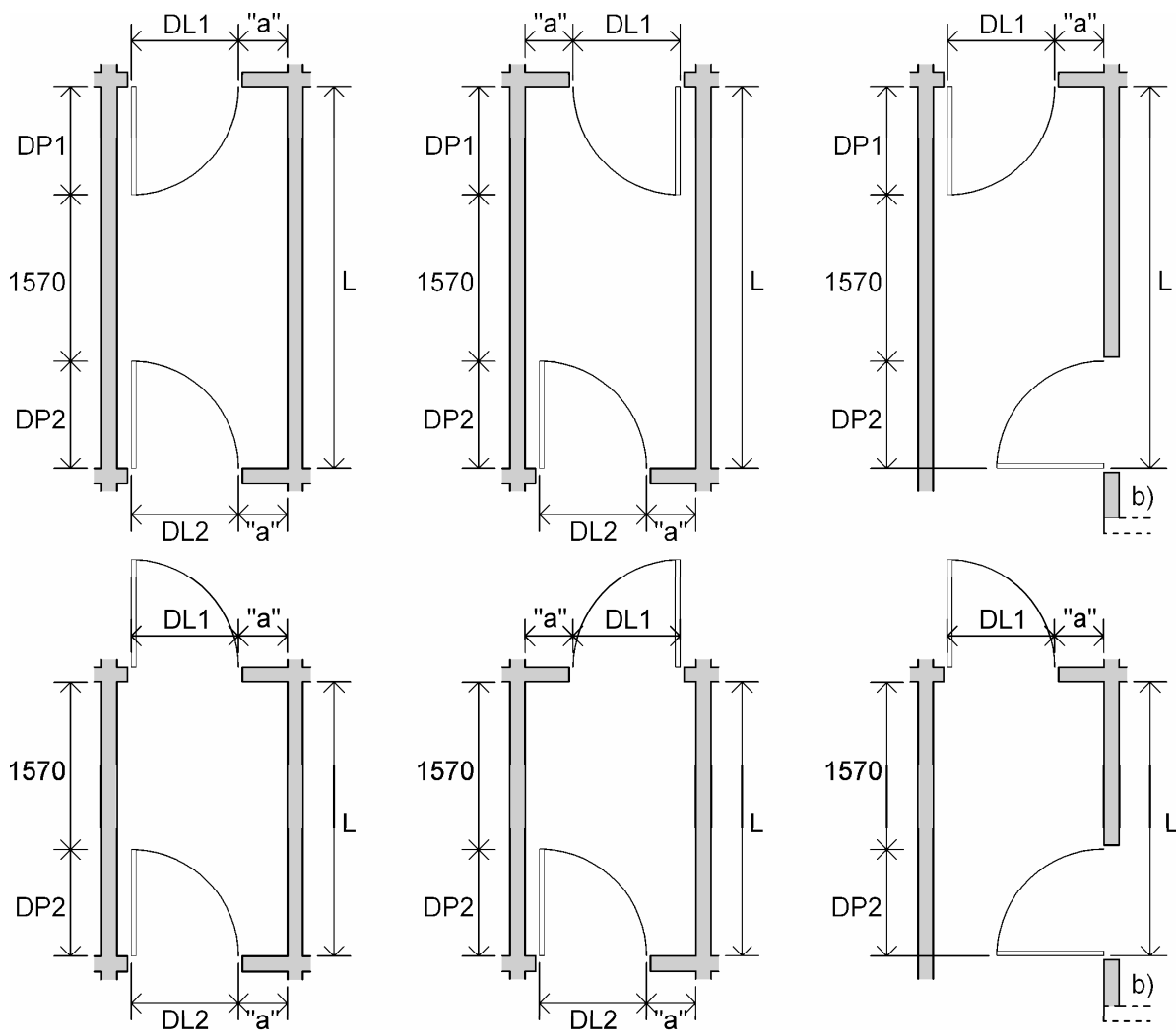

DL1 and DL2 = door leaf dimensions of the doors to the lobby

DP1 and DP2 = door projection into the lobby (normally door leaf size)

L = minimum length of lobby, or length up to door leaf for side entry lobby

"a" = at least 300 mm wheelchair access space (can be increased to reduce L)

1570 mm = length of occupied wheelchair with a companion pushing (or a large scooter).

b) No return wall within 600 mm of the doorway to enable a wheelchair user to manoeuvre into a position straight onto the door.

NB: For every 100 mm increase above 300 mm in the dimension "a" (which gives a greater overlap of the wheelchair footprint over the door swing), there can be a corresponding reduction of 100 mm in the dimension L, up to a maximum of 600 mm reduction.

Lobby dimensions should be clear of any elements that project into the lobby



# Section 1.3

## Circulation within buildings other than dwellings

---

### **Section 1.3** **Circulation within buildings other than dwellings.**

#### **1.3.1 Objective**

**The objective is for people to travel horizontally and vertically within a building conveniently and without discomfort in order to make use of all relevant facilities.**

#### **1.3.2 Introduction**

An entrance hall and reception area is the first point of contact and a source of information for many when arriving at a building and should be accessible to all.

Corridors, passageways and internal lobbies should facilitate a free flow of people around a building. Doors along internal circulation routes can create barriers for people, particularly for those with limited upper body strength, and should only be provided where necessary. However, where they are necessary, for the purposes of compliance with Part B – Fire Safety, they should be easy to use and/or held open on electronic hold-open devices.

Appropriate directional signage indicating the location of the various facilities within the building should be provided where necessary (refer to 1.6.3).

Each storey of a building should be so designed and constructed as to allow for independent circulation by people with a wide range of abilities and independent access to the range of accessible services and facilities provided on that storey.

Where a change of level within a storey of a building is necessary because of site

constraints or design considerations, a suitable means of access should be provided between the levels by a gently sloped access route, a ramp and steps or a platform lift.

A passenger lift is a convenient means for many people including those pushing buggies, using wheelchairs and carrying luggage, to travel from one floor to another in order to access all relevant facilities. Passenger lifts should be provided in all multi-storey buildings (some exceptions are provided in 1.3.4.1.1).

At least one stairs suitable for ambulant disabled people should also be provided to all floors above and below the entrance level to provide a choice for users.

Guidance is given in this section on the features and characteristics of internal circulation areas, required to make them accessible to people with a wide range of abilities.

Section 1.3.3 deals with internal horizontal circulation features such as; entrance hall and reception areas; internal doors; corridors and passageways and internal lobbies.

Section 1.3.4 deals with internal vertical circulation features such as; passenger lifts; internal stairs suitable for ambulant disabled people; internal ramps and handrails.

#### **1.3.3 Horizontal features**

##### **1.3.3.1 Reception area in entrance halls**

As the entrance hall is the first point of contact with a buildings activities and resources, the reception area should not only be accessible but also convenient to

## Section 1.3

### Circulation within buildings other than dwellings

---

use. Where a reception area is provided in an entrance hall:

- (a) it should be easily identified from the entrance;
- (b) concise signs and universally accepted symbols or pictograms indicating the location of stairs, WCs, circulation routes and other parts of the building should be provided;
- (c) it should have a direct and unobstructed accessible route from the entrance;
- (d) in order to facilitate wheelchair users, it should have a clear manoeuvring space in front of a reception desk or counter of:
  - (i) 1200 mm deep x 1800 mm wide, if there is a knee recess of at least 500 mm deep, or
  - (ii) 1400 mm deep by 2200 mm wide if there is no knee recess;
- (e) it should be designed to facilitate people both standing and seated (e.g. wheelchair users and for people of short stature). If a desk or counter is used it should have a working surface height at two levels as follows:
  - (i) between 950 mm and 1100 mm high to facilitate people who are standing.
  - (ii) 760 mm maximum height to facilitate wheelchair users and people of short stature;
- (f) at least one low level section should have a minimum length of 1800 mm on the main reception counter. Rationale: A low level counter, 1800 mm long will facilitate two wheelchairs alongside each other or facing each other across the counter diagonally;
- (g) it should also have a knee recess to not less than 700 mm above floor level. This should be provided on both sides to facilitate both staff and visitors alike. The minimum working surface depth should be 700 mm. To avoid excessive depths of work surfaces, knee spaces for customers and receptionists, both wheelchair users, should not be arranged opposite each other;
- (h) in buildings where it is not necessary to sign in or transact business across the desk, it is acceptable to have a lowered counter with the knee recess on the staff side only. The length of the low level counter may be reduced to 900mm in this case;
- (i) it should have a hearing enhancement system e.g. an audio frequency induction loop system and clear signage should be provided to indicate its presence (refer to 1.6);
- (j) the floor surface should be slip resistant (refer to BS 8300:2009 Annex E);
- (k) glazed screens in front of reception points should be avoided except where required for security reasons. Windows, glazed screens, reflective or patterned wall surfaces located

# Section 1.3

## Circulation within buildings other than dwellings

---

behind the reception point should also be avoided.

Rationale: These surfaces can compromise the ability of a person to lip read or follow sign language.

### 1.3.3.2 Internal doors

Doors can create barriers for people, particularly for those with limited upper body strength, and therefore should only be provided where necessary.

Self-closing devices create particular difficulties for some people (refer to Section 1.2) and their use on internal doors should be minimised. While these devices are generally required on fire doors, TGD B gives guidance on acceptable methods of holding them open, where a self-closing device is considered a hindrance to the normal use of a building. Refer to TGD B, Annex B, Fire Doors, Self-closing devices, B3 for guidance. Fire doors should be held open in accordance with this guidance, where possible, in areas of the building frequently used by the public.

Where internal doors are provided to wheelchair accessible areas:

- (a) the opening force when measured from the leading edge of the door, should be not more than 30N from 0° (the door in the closed position) to 30° open, and not more than 22.5N from 30° to 60°degrees of the opening cycle<sup>5</sup>. Doors that have a requirement to self-close for reasons of fire and smoke control, privacy, acoustics or energy control, should have closing devices fitted and adjusted so that the opening forces are well below the limits set above, consistent with the door functioning as intended. Care should be taken

to ensure that controlled door closing devices allow the door to open to provide the required effective clear width;

- (b) the effective clear width through a single leaf door or one leaf of a double leaf door should be in accordance with Table 2 and Diagram 10;
- (c) there should be an unobstructed space of at least 300 mm on the pull side of the door between the leading edge of the door (when it opens towards you) and a return wall, unless the door is opened by remote automatic control or it provides access to a standard hotel bedroom or en-suite, standard, enlarged cubicle, cubicles for ambulant disabled people, storage or maintenance area;
- (d) door handles should be located at a height of between 800 mm and 1050 mm (900 mm preferred) above finished floor level. Where a pull handle is provided the available grip zone of the pull handle should be between 700 mm (min) to 1000 mm (max) above finished floor level. The top end of the pull handle should be 1300 mm (min) above finished floor level. Where fitted with a latch, the door opening furniture should be operable with the closed fist of one hand or an elbow e.g. a lever handle;

---

<sup>5</sup> The accuracy of force measuring instruments available on the market varies. There are also inherent difficulties in measuring forces on site. It is recognised, therefore, that any measurements will be subject to a degree of imprecision which could give rise to variations of between 2 and 3 N.

## Section 1.3

### Circulation within buildings other than dwellings

---

- (e) all door opening furniture should contrast visually with the surface of the door (refer to 1.6.4);
- (f) the door, door frames or architrave should contrast visually with the surrounding wall (refer to 1.6.4);
- (g) the surface of the leading edge of any door that is not self-closing, or is likely to be held open, should contrast visually with the other door surfaces and its surroundings so it does not create a hazard (refer to 1.6.4).  
Rationale: This ensures that people with vision impairment can still identify the door opening within the wall;
- (h) where possible, unless for reasons of security or privacy, door leaves and side panels wider than 450 mm should have vision panels towards the leading edge of the door whose vertical dimensions include at least the minimum zone or zones of visibility between 500 mm and 1500 mm from the floor. If a door has multiple viewing panels, the minimum zone of visibility should not be interrupted by opaque areas that obstruct more than 350 mm of the vertical height of the zone. Refer to Section 1.2.4 and Diagram 10.  
Rationale: This allows a person to see another person approaching in the other direction in time to avoid a collision. The extent of the visibility zone facilitates people of all heights or those using a wheelchair;
- (i) frameless glass doors or fully glazed framed doors with a narrow stile, should comply with 1.2.4.1;

- (j) a low energy powered swing door system should comply with 1.2.4.4;
- (k) refer to TGD B for the direction of opening on doors on escape routes.

#### 1.3.3.3 Corridors and passageways

A corridor or passageway should be wide enough to allow people to pass each other, taking into account common activities and mobility aids such as people pushing buggies, using a wheelchair or walking frame, carrying luggage or using crutches. A corridor that is 1500 mm wide will allow a wheelchair user and an ambulant person to pass one another. A corridor that is 1800 mm wide will allow two wheelchair users to pass one another. Wheelchair users or people pushing buggies should have adequate space available to turn into adjoining spaces or to turn through 180 degrees.

Where corridors and passageways are provided:

- (a) the unobstructed clear width should be at least 1200 mm. Elements such as columns, radiators and fire hoses should not project into this corridor width;
- (b) passing places should be provided where the unobstructed width of the corridor is less than 1800 mm. Passing places should have a total unobstructed width of corridor of 1800 mm wide over an 1800 mm length. Passing places should be provided:
  - (i) at reasonable intervals, not more than 20 m apart;
  - (ii) at junctions; and

## Section 1.3

### Circulation within buildings other than dwellings

---

- (iii) at ends of corridors.
- Rationale: This will allow wheelchair users to turn in the opposite direction and to pass each other (refer to Diagram 12);
- (c) the floor should be level. For the purpose of this guidance document a gradient of 1:50 or less steep is considered to be level;
- (d) where a section of the floor has a gradient in the direction of travel, steeper than 1:50 but less steep than 1:20 it is defined as gently sloping and a level rest area of at least 1800 mm long should be provided at each rise of 500 mm. Where this is not possible refer to 1.3.4.4 internal ramps;
- (e) any section with a gradient of 1:20 or steeper should be designed as a ramp (refer to 1.3.4.4);
- (f) any gently sloping section should extend the full width of the corridor, otherwise the exposed edge should be clearly identified and contrast visually (refer to 1.6.4). Where necessary, it should be protected by guarding;
- (g) any door opening towards a corridor which is a major access route or an escape route should be recessed so that when fully open, it does not project into the corridor space except where the doors are minor utility facilities such as small store rooms and locked duct cupboards. Rationale: This is to avoid collisions with passers-by;
- (h) if the door from the unisex accessible WC opens into a corridor that is not a major access route or an escape route, there should be a clear width remaining in the corridor as illustrated in Diagram 12. Rationale: To allow a person using a wheelchair to manoeuvre out the door into the corridor;
- (i) on a major access route or an escape route, the wider leaf of any series of double doors placed across the route, having leaves of unequal width, should be on the same side of the corridor throughout the length of the corridor;
- (j) floor surface finishes should be slip resistant. Refer to Annex E of BS 8300:2009;
- (k) any full height glazed screens alongside a corridor or passageway should be clearly defined with manifestation on the glass at two levels, 850 mm to 1000 mm and 1400 mm to 1600 mm contrasting visually (refer to 1.6.4) with the background seen through the glass in all lighting conditions (refer to 1.6.5);
- (l) clear unobstructed headroom of 2100 mm (except for any door frame) should be provided to prevent people colliding with projecting edges at head height. Where a stairway crosses over a circulation route, suitable precautions should be taken to ensure that any part of the area under the stairway with a height lower than 2100 mm cannot be used for circulation purposes. The area should be enclosed, protected by guarding and low level cane
-

## Section 1.3

### Circulation within buildings other than dwellings

---

detection or a permanent barrier giving the same degree of protection.

- (m) corridors and passageways should be adequately lit. Artificial lighting for corridors and passageways that receive no daylight should be designed to achieve an illuminance at floor level of at least 100 lux (refer to 1.6.5);
- (n) where seating and/or handrails are provided in long corridors i.e. over 20 m, a minimum clear corridor width of 1200 mm should be maintained.

#### **1.3.3.4 Internal lobbies**

Internal lobbies to wheelchair accessible areas should be in accordance with entrance lobbies in 1.2.5.

# Section 1.3

## Circulation within buildings other than dwellings

**Diagram 12 Dimensions and space allowances for corridors in buildings other than dwellings**

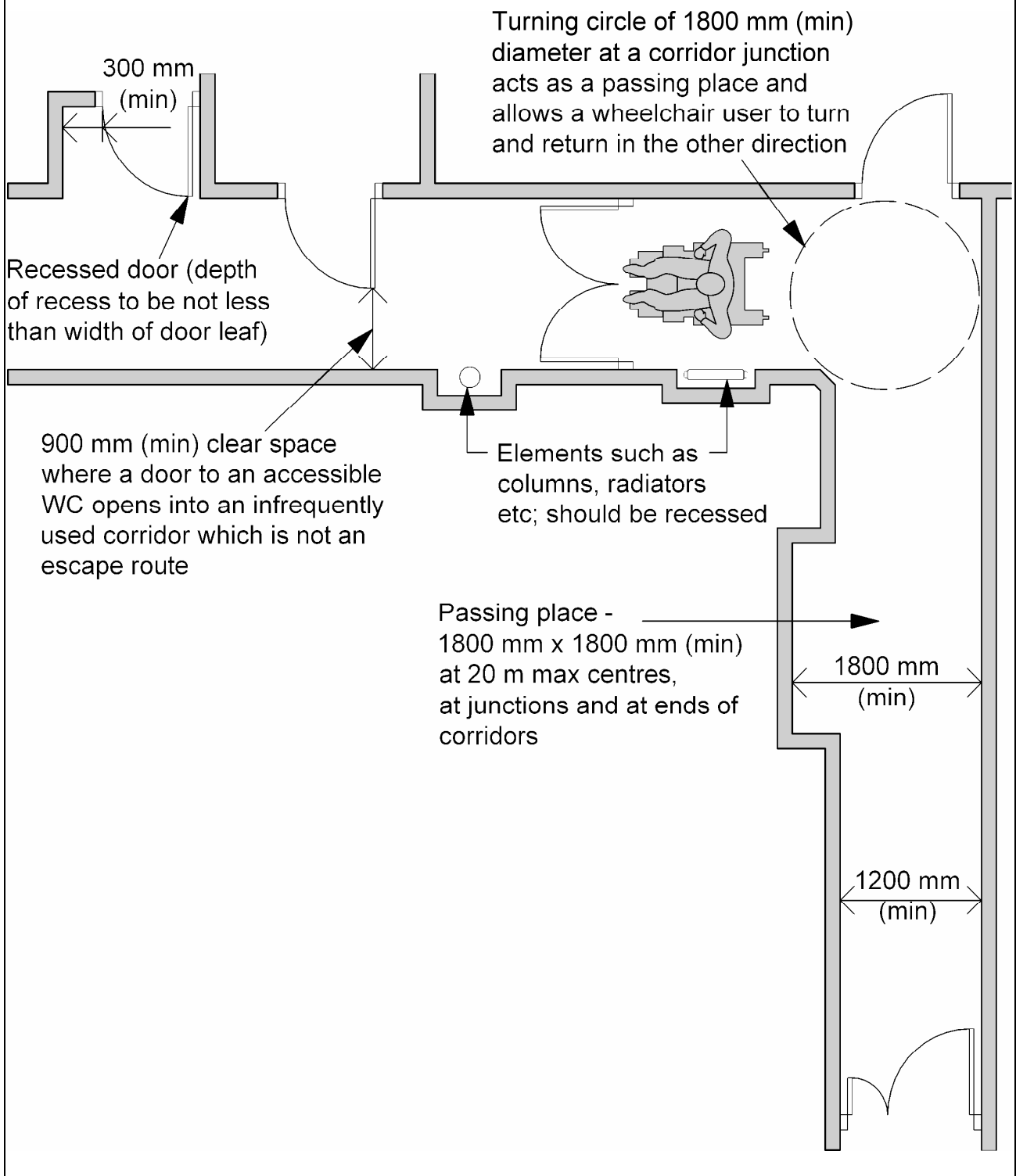

## Section 1.3

# Circulation within buildings other than dwellings

---

### 1.3.4 Vertical features

#### 1.3.4.1 Provision

A passenger lift is the most accessible means of vertical circulation and allows people with a wide range of abilities to travel conveniently and without discomfort from floor to floor in order to make use of all relevant facilities.

##### 1.3.4.1.1 Lifts

Passenger lifts should be provided in all multi-storey buildings to serve all storeys above and below entry level e.g. basements used for car parking, etc, except in the following situations:

- (a) non-residential or mixed use buildings with a nett floor area per floor of less than 200 m<sup>2</sup> and with no floor having an entrance level more than 4500 mm above or below the main entrance level, or
- (b) apartment buildings with four (or less) dwellings on any storey other than the entrance storey and with no dwelling having an entrance level more than 4500 mm above or below the main entrance level.
- (c) duplex buildings with two (or less) dwellings on any one storey other than the entrance storey and with no dwelling having an entrance level more than 6500 mm above or below the main entrance level.

Buildings in cases (b) and (c) above are generally apartment or duplex buildings containing dwellings only, however they may incorporate mixed use elements at the entrance storeys e.g. retail units, etc.

In calculating the nett floor area for non-residential and mixed use buildings the areas of all parts of a storey (including

any apartments) should be added together, whether they are in more than one part of the same storey or used for different purposes. The area of any vertical circulation, common sanitary facility and maintenance areas in the storey should not be included.

Consideration should be given to other lifting devices, such as lifting platforms that facilitate vertical travel to facilities, especially in buildings to which the exceptions (a) to (c) above apply. Lifting platforms should comply with 2.3.4.1.1. For further information on these devices refer to 'Building for Everyone'.

Reference should be made to Part B and TGD B for guidance on fire related issues associated with lifts e.g. lifts to underground car parks, etc. Refer to TGD B – General Provisions for means of escape.

Where no lift or lifting device is provided, the same range of services/ facilities that are available on the other levels should be made available on the entry or accessible level.

##### 1.3.4.1.2 Stairs

In addition to the provision of a passenger lift, at least one internal stairs suitable for ambulant disabled people should also be provided as an alternative means of vertical access. Refer to 1.3.4.3 for details.

##### 1.3.4.2 Passenger lift details

In the case of places of work, designers should have regard to the Safety, Health and Welfare at Work (General Application) Regulations 2007 (S.I. No. 299 of 2007) which requires testing, examination, certification and regular inspection of lifts. Passenger lifts should



## Section 1.3

### Circulation within buildings other than dwellings

---

comply with the Lift Directive 95/16/EC.

Where an accessible passenger lift is provided:

- (a) it should conform with I.S. EN 81-1; I.S. EN 81-2 and I.S. EN 81-70;
- (b) it should be approached via an accessible horizontal circulation route in accordance with Section 1.3;
- (c) signs should be provided to facilitate finding the lift;
- (d) lift landing and lift car doors should contrast visually with the adjoining walls (refer to 1.6.4);
- (e) there should be a clear unobstructed space for manoeuvring at least 1800 mm wide and at least 1800 mm deep in front of every entrance door to the lift;
- (f) lift car doors should be power-operated horizontal sliding doors;
- (g) lift car doors should have a clear opening width of at least 800 mm;
- (h) lift car doors should be fitted with timing devices and re-opening activators allowing the doors to stay open for at least 8 seconds. In addition a device should be provided both within the lift car and on the landing to enable the door to be kept open for longer if necessary.  
Rationale: To allow adequate time for people and any assistance dogs to enter and leave;
- (i) the minimum internal dimensions of a lift car should be 1100 mm wide x 1400 mm deep.  
Rationale: This size accommodates manual and electrically powered wheelchairs and one accompanying person;
- (j) a larger lift car should be provided in the public areas of public facilities such as hotels, cinemas, theatres shopping centres and public libraries, where the public area has a nett floor area per floor of greater than 200 m<sup>2</sup>. The larger lift car dimensions should be 2000 mm wide x 1400 mm deep.  
Rationale: The larger lift car will facilitate most types of wheelchairs; scooters and buggies, along with several other passengers;
- (k) the controls in the lift car should be positioned at a height of not less than 900 mm, not more than 1200 mm (preferably 1100 mm) above the car floor and at least 500 mm from any return wall;
- (l) the call buttons at each landing should not be less than 900 mm and not more than 1100 mm above the landing. Controls should not be located in corners and should be at least 500 mm from any wall or projecting surface.  
Rationale: This will facilitate a person in a wheelchair reaching the buttons;
- (m) suitable tactile indicators for floor numbers should be provided on or adjacent to lift buttons within the lift car and on the landing;
- (n) the landing call button symbols and control button symbols should be raised to facilitate tactile reading;

## Section 1.3

### Circulation within buildings other than dwellings

---

- (o) all call and control buttons should contrast visually with the surrounding face plate and similarly, the face plate should contrast visually with the surface on which it is mounted (refer to 1.6.4);
- (p) the floor of the lifting device should not be a dark colour.  
Rationale: This can create the illusion, for people with vision impairment, of stepping into an open lift shaft);
- (q) the lifting device floor should be slip resistant and have frictional qualities similar to or higher than the floor finish of the landing;
- (r) the lift car and lift lobby should provide both visual and auditory warning of the lift cars arrival and the number of the floor level reached prior to the doors opening;
- (s) a half-length mirror should be installed on the wall opposite the lift door (where the lift car is not a through lift) with the bottom edge of the mirror being between 900 mm to 950 mm above the lift car floor.  
Rationale: This avoids confusion for people with vision impairment and to provide a wheelchair user with a rear view to safely reverse out from the lift car;
- (t) a handrail of contrasting colour with its surroundings should be provided on at least one wall with its top surface at 900 mm above the floor and located so that it does not obstruct the controls or the mirror. Handrails should be terminated in such a way that reduces the risk of clothing being caught;
- (u) a suitable emergency communication system should be installed. Systems should be easy to use for example intercom and push button activation and contain inductive couplers.  
Rationale: So that people using hearing aids can make use of them;
- (v) the illumination in the lift car should minimise glare, reflection, confusing shadows or pools of light and dark.  
Rationale: Areas of glazing should be identifiable by people with vision impairment.

# Section 1.3

## Circulation within buildings other than dwellings

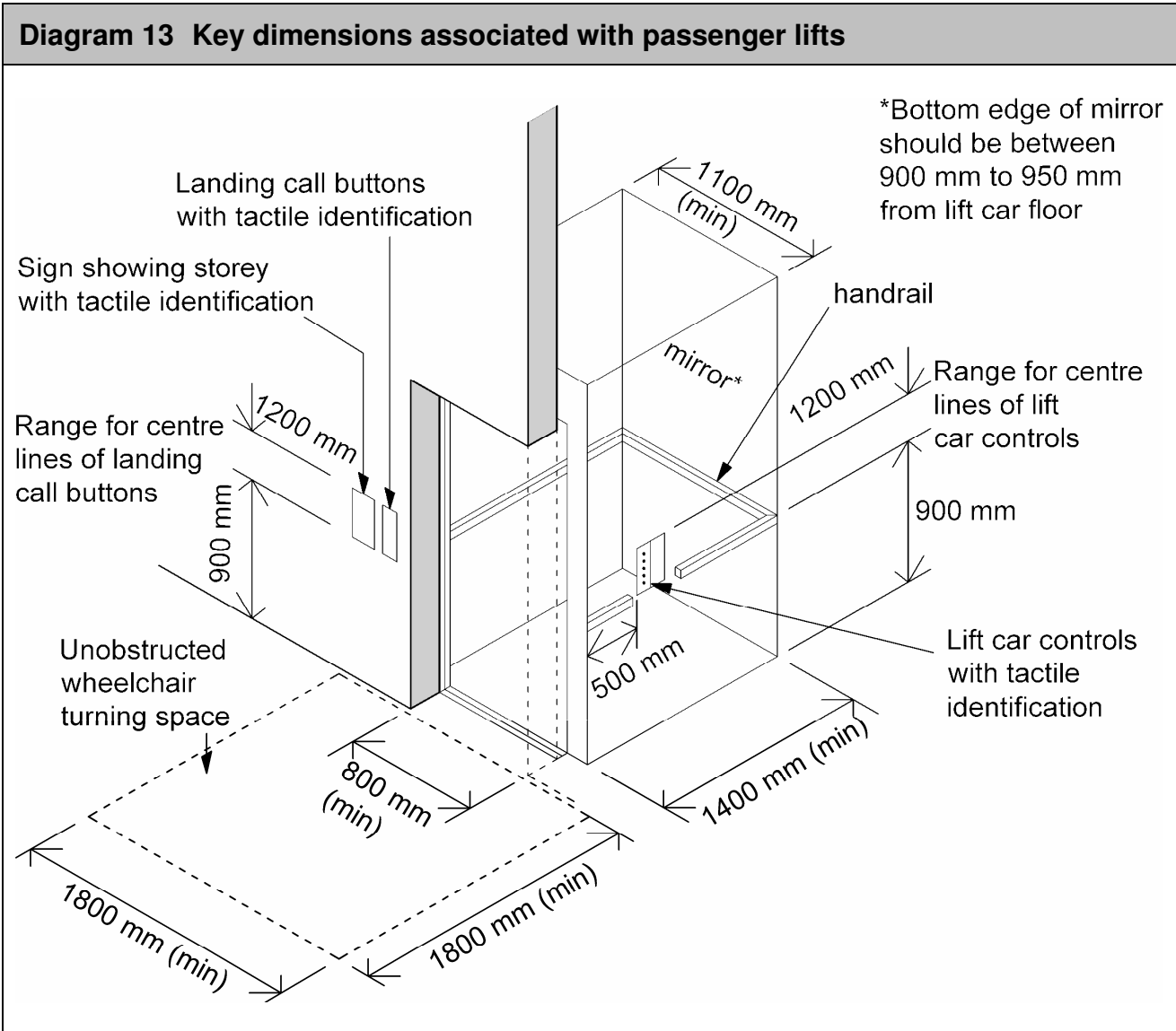

### 1.3.4.3 Internal stairs suitable for ambulant disabled people

At least one set of stairs suitable for ambulant disabled people should be provided to access all floors above or below entrance level in a building.

Stairs serve many different functions in a building e.g. a means of escape, a means of access for ambulant disabled people or an effective, efficient and simple means of vertical circulation, or sometimes a combination of these. Functional requirements and guidance on compliance for stairs are given in

various Parts of the Building Regulations namely Part B for escape, Part K for stairs in general and Part M for stairs suitable for ambulant disabled people. Designers should refer to the relevant Part and accompanying TGD when designing stairs.

Particular reference should be made to Part B/ TGD B for the provision of refuges for people with disabilities.

## Section 1.3

### Circulation within buildings other than dwellings

---

Where internal stairs suitable for ambulant disabled people are provided:

(a) the minimum clear width (between enclosing walls, strings or upstands) should be 1200 mm;

(b) a landing should be provided at the top and bottom of each flight;

(c) the landings should be level and have an unobstructed length (clear of any door swing) of at least 1200 mm or the width of the flight whichever is greater;

(d) there should be no single steps;

(e) the rise of a flight between landings should not exceed 1800 mm;

(f) all step nosings should incorporate a permanently contrasting continuous material on the tread. The material should be between 50 mm and 65 mm wide on the tread and should visually contrast with the remainder of the tread (refer to 1.6.4).

Rationale: This will help people with vision impairment to appreciate the extent of the stair and identify the individual treads;

(g) projecting or overhanging step nosings should be avoided.

Rationale: Nosings can cause people to trip or catch their feet. Refer to Diagram 5 for acceptable tread and riser profiles;

(h) the rise and going of each step should be consistent throughout a flight;

(i) the rise of each step should be between 150 mm and 180 mm and

have a going of at least 300 mm.

Rationale: A larger going helps avoid accidents on a stair particularly on descent, as it allows a person to place more of their foot on the step;

(j) tapered treads and open risers should not be used as they create a sense of insecurity for people with vision impairment;

(k) there should be a continuous handrail on each side of flights and landings in accordance with 1.1.3.6. The minimum unobstructed width between handrails should be not less than 1000 mm;

(l) where the overall unobstructed width (width between handrails) is more than 2000 mm, additional handrails should be used to divide the internal stairs into channels of unobstructed width not less than 1000 mm and not greater than 2000 mm.

Rationale: This provides for a person with less strength on one side to be within easy reach of support;

(m) the surface of the treads should be slip resistant, especially when wet. Guidance on slip resistance is given in BS 8300:2009 Annex E;

(n) the illuminance at tread level should be at least 100 lux;

(o) there is no guidance on hazard warning surfaces at the head of internal stairs as there is no recognised warning/hazard surface for internal use that can be guaranteed not to constitute a trip hazard when used alongside flooring

## Section 1.3

### Circulation within buildings other than dwellings

with different frictional resistances.

Therefore, where possible, internal stairs should not be directly in line with an access route.

Rationale: Due to the potential risk that people will not recognise the stairs in time;

- (p) where the area beneath a stairs has a soffit height less than 2100 mm above floor level, it should be enclosed or guarded to prevent access.

Rationale: To reduce the risk to people especially those with vision impairments colliding with the edge of the stairs soffit.

**Diagram 14 Key dimensions associated with internal stairs suitable for ambulant disabled people**

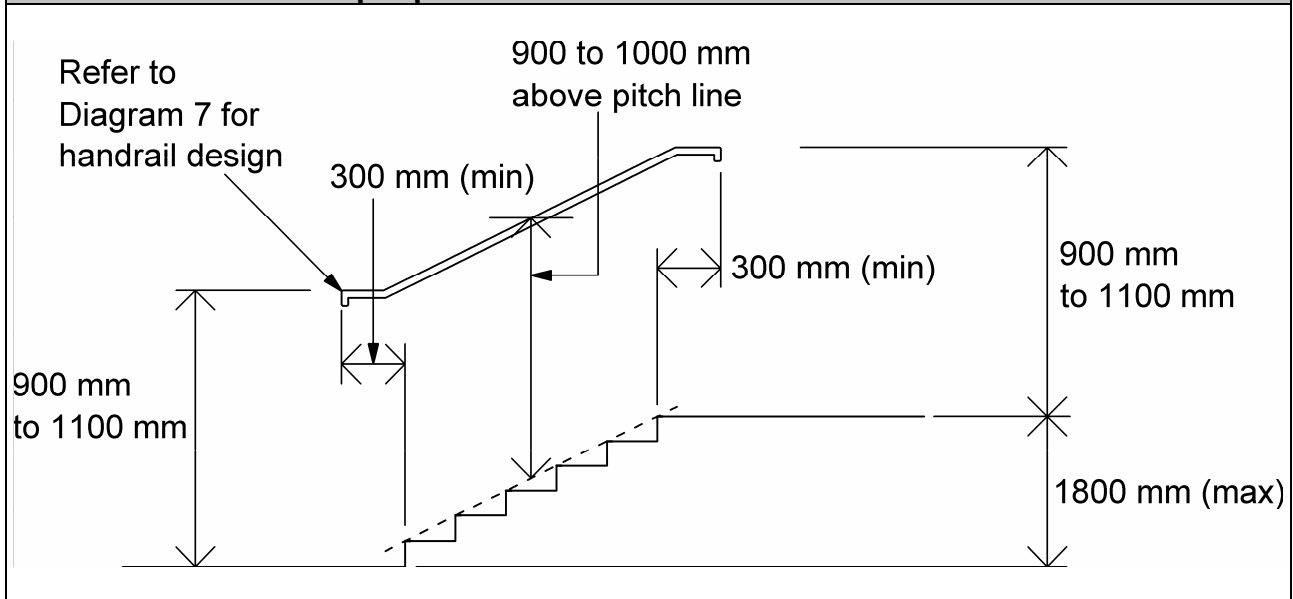

## Section 1.3

### Circulation within buildings other than dwellings

---

#### 1.3.4.4 Internal ramps

If a change in level is unavoidable within a storey a gentle slope should be provided (refer to 1.3.3.3 (d)). Where this is not possible and the change in level is 300 mm or more, two or more clearly defined steps (in accordance with 1.3.4.2) identifiable by means of visual contrast (refer to 1.6.4) should be provided in addition to a ramp.

A ramp is defined as a gradient of 1:20 or steeper. Limits for ramp gradient and flight length are defined in Table 1. Where the change in level is not greater than 300 mm, a ramp alone is sufficient.

Where an internal ramp is provided

- (a) it should comply with guidance given for external ramped access routes in 1.1.3.4;
- (b) it should be easy to locate or clearly sign-posted;
- (c) it should have no flight with a going greater than 10 m or a rise of more than 500 mm (refer to Table 1 and Diagram 3).
- (d) where the area beneath a ramp has a soffit height less than 2100 mm above floor level, it should be protected by either enclosure, guarding and low level cane detection or a permanent barrier giving the same degree of protection.

#### 1.3.4.5 Handrails

A suitable continuous handrail should be provided on each side of flights and landings of internal stairs suitable for ambulant disabled people and ramps. Refer to TGD K for guidance on the provision of guarding. Handrails should comply with guidance given for external handrails in 1.1.3.6.

# Section 1.4

## Sanitary facilities for buildings other than dwellings

---

### Section 1.4 Sanitary facilities for buildings other than dwellings.

#### 1.4.1 Objective

**The objective is to provide independently accessible sanitary facilities that meet the needs of people with a wide range of abilities.**

#### 1.4.2 Introduction

For the purposes of this part specific guidance on the provision of sanitary facilities is given in 1.4.3. Detailed guidance on the design of the sanitary facilities is given in 1.4.4 to 1.4.9.

#### 1.4.3 General provisions

The number and location of sanitary facilities required in a building will be dictated by the nature of the building, the size of the building, the number of people who will use the building, gender ratio, patterns of use and the ease of access. Refer to Part G/ TGD G for the scale of provisions for sanitary facilities. In the case of places of work, designers should also have regard to the Safety, Health and Welfare at Work (General Application) Regulations, 2007 (S.I. No. 299 of 2007).

Section 1.4.3 requires the provision of accessible sanitary facilities where sanitary facilities are provided in a building, whether this is for customers, visitors, or staff working in the building. It does not create a requirement for the provision of sanitary facilities in a building or for different user groups e.g. for visitors where provision has only been made for staff.

The following guidance represents the minimum provisions to ensure that

sanitary facilities where provided for a particular user group, are accessible to all in that group e.g. customers and/or staff.

The guidance is based on providing a minimum clear turning space of 1800 mm x 1800 mm for a wheelchair. This space provision will be adequate for many wheelchairs, however some powered wheelchairs and scooters may require larger turning spaces.

A wheelchair accessible unisex WC is designed to meet the needs of independent wheelchair users, but it is also equipped to suit ambulant disabled people. In addition it may be used by people who require additional space, the support of grab rails or integral hand washing facilities. A unisex facility enables assistants of either sex to assist a person with a disability.

In addition to the above, 1.4.3.1 to 1.4.3.5 outline the provisions required in relation to specific types of sanitary facilities.

In primary school buildings where WCs are provided within the classroom provision should be made for ambulant disabled people. In addition, a minimum provision of one wheelchair accessible unisex WC should be made, either as part of the classroom environment or in the common areas of the building. The travel distance to this WC should be minimised where it is not located within the classroom. For further requirements on sanitary facilities in primary schools, refer to the Department of Education and Skills Technical Guidance Documents available on [www.education.ie](http://www.education.ie).

Sanitary facilities used solely for individual use within offices are not covered in the following sections however; consideration should be given

# Section 1.4

## Sanitary facilities for buildings other than dwellings

---

to meeting the needs of the user.

### 1.4.3.1 Provisions for wheelchair accessible unisex WCs

The provisions for wheelchair accessible unisex WCs are as follows:

- (a) Buildings with a nett floor area per floor greater than 200 m<sup>2</sup> should provide a wheelchair accessible unisex WC with minimum turning space of 1800 mm x 1800 mm (Refer to Diagram 15a). Buildings with a nett floor area per floor of 200 m<sup>2</sup> or less may provide a minimum turning space of 1500 mm x 1500 mm (Refer to Diagram 15b). Where space permits, a turning space in excess of 1500 mm x 1500 mm should be considered. In calculating the nett floor area the area of any vertical circulation, common sanitary facility and maintenance areas in the storey should not be included;
- (b) Where there is only one WC facility provided in the building, it should be unisex, wheelchair accessible and incorporate a standing-user height washbasin, in addition to the finger rinse basin associated with the WC pan.  
Rationale: This provision will facilitate the needs of a wider range of users;
- (c) Where there is more than one WC facility provided in a building at different locations, at least one wheelchair accessible unisex WC should be provided at each location;
- (d) Where independent access to storeys, above or below the entrance storey, is not available for wheelchair users, i.e. if access is by

stairway only, a wheelchair accessible unisex WC should be located on the entrance storey, except where the entrance storey contains only the entrance and vertical circulation areas. However, in every such building, provision for a WC for ambulant disabled people should still be made;

- (e) Where more than one wheelchair-accessible unisex WC is provided, the layouts should be handed.  
Rationale: This facilitates both left and right handed transfer techniques onto the WC. For further information on transfer techniques refer to 'Building for Everyone';
- (f) Where wheelchair accessible unisex WCs are provided, they should meet the minimum requirements set out in 1.4.4 and 1.4.5.

### 1.4.3.2 Provisions for WC cubicles

The provisions for WC cubicles are as follows:

- (a) Where WC cubicles are provided in a washroom, at least one WC cubicle should be provided for ambulant disabled people amongst the standard cubicles in each washroom as per 1.4.6.1 and 1.4.6.2;
- (b) Where four or more WC cubicles are provided in a washroom, one WC cubicle should be an enlarged cubicle for use by people who need extra space in addition to the requirement in (a) above.  
Rationale: Enlarged cubicles are not a substitute for cubicles suitable for ambulant disabled people but rather an alternative arrangement to



## Section 1.4

### Sanitary facilities for buildings other than dwellings

---

meet the needs of people with another range of abilities;

- (c) If there is more than one enlarged WC cubicle provided, layouts should be handed as the WC is offset.

Rationale: This facilitates people who are stronger on one side;

- (d) Where WC cubicles are provided, they should meet the minimum requirements set out in 1.4.4 and 1.4.6.

#### 1.4.3.3 Provisions for urinals

The provisions for urinals are as follows:

- (a) Where one or more urinals are provided in a washroom, at least one urinal should be suitable for use by ambulant disabled people;

- (b) Where six or more urinals are provided in a washroom at least one accessible urinal and one low wash hand basin should be provided for wheelchair users in addition to the requirements in (a) above;

- (c) Where urinals are provided, they should meet the minimum requirements set out in 1.4.4 and 1.4.7.

#### 1.4.3.4 Provisions for accessible bathrooms/shower rooms

The provisions for accessible bathrooms/shower rooms are as follows:

- (a) Where an en suite sanitary facility is provided in an accessible bedroom for independent use by a wheelchair user e.g. in hotels, guest accommodation, residential accommodation, medical facilities

etc, the sanitary facility should be in accordance with 1.4.8 (For information on the provision of accessible bedrooms in hotels (refer to 1.5) ;

- (b) A balanced combination of en-suite bathrooms and en-suite shower rooms should be provided when more than one en-suite bathroom or shower room is provided. If only one accessible en-suite facility is provided, it should include an accessible shower, rather than a bath.

Rationale: Many people with disabilities and elderly people may find it easier to use a shower;

- (c) A choice of layouts suitable for left-hand and right-hand transfer should be provided when more than one en-suite bathroom or shower room is provided;

- (d) Where a sanitary facility combining showers/baths and WCs is provided in a building, e.g. hotels, hospitals, student accommodation, sports, leisure facilities, an accessible shower room or bathroom as per 1.4.8 should be provided. When more than one of each type is provided a choice of layouts suitable for left-hand and right-hand transfer should be provided. This should not be the only wheelchair accessible WC in the building;

- (e) Where accessible bathrooms/shower rooms are provided, they should meet the minimum requirements in 1.4.4 and 1.4.8.

# Section 1.4

## Sanitary facilities for buildings other than dwellings

---

### 1.4.3.5 Provisions for changing and/or showering facilities

The provisions for changing and/or showering facilities are as follows:

- (a) Where communal separate-sex changing and/or showering facilities are provided, accessible changing and/or showering facilities should be provided in communal areas by subdividing the area and providing accessible space and fittings as for self-contained facilities as per 1.4.9;
- (b) In sport facilities, accessible individual unisex self-contained showering and/or changing facilities should be provided as per 1.4.9 in addition to communal separate-sex facilities. Where it is not practicable to provide both communal and individual facilities, an individual unisex and accessible showering and/or changing facility as per 1.4.9 should be provided. A choice of layouts suitable for left-hand and right-hand transfer should be provided when more than one changing and/or showering facility is provided.

### 1.4.4 Sanitary facilities – General

The space provided for manoeuvring and the relative positioning of WCs, wash basins and other accessories is critical to enable wheelchair users or people with mobility impairment to adopt various transfer techniques that allow independent or assisted use of sanitary facilities. The guidance given in the following sections provides acceptable sample sizes and layouts for the situations called up in 1.4.3 above.

For further information on accessible

sanitary facilities refer to BS 8300:2009 and Building for Everyone.

Where accessible sanitary facilities are provided:

- (a) accessible sanitary facilities should be located in a convenient and accessible part of the building. Refer to 1.1 to 1.3 for approach, access and circulation routes;
- (b) accessible sanitary facilities should be clearly identifiable.  
Rationale: People with difficulty communicating may prefer not to ask directions and should therefore be able to rely on signage (refer to 1.6.3);
- (c) any bath, shower or washbasin tap should be either controlled automatically or be capable of being operated using a closed fist e.g. by lever action;
- (d) any door handles and other ironmongery should comply with the requirements for internal doors in 1.3.3.2. Where fitted with a latch, the door opening furniture should be capable of being operated with one hand using a closed fist e.g. a lever handle. All door opening furniture should contrast visually with the surface of the door (refer to 1.6.4);
- (e) doors to accessible sanitary facilities should be fitted with light action privacy bolts so that they can be operated by people with limited dexterity. Where doors to accessible sanitary facilities are required to self-close, they should meet the provisions of 1.3.3.2 (a);

## Section 1.4

### Sanitary facilities for buildings other than dwellings

---

- (f) it is preferable to have outward opening doors (or sliding doors) to accessible sanitary facilities. If inward opening doors are used, the size should be increased to ensure that the swing of the inward opening door does not encroach into the wheelchair turning space/ activity space or transfer area;
- (g) outward opening doors should be fitted with a horizontal pull rail fixed to the inside face and should not project into circulation routes or obstruct emergency escape routes;
- (h) doors to accessible sanitary facilities should have an emergency release mechanism e.g. lifting off hinges  
Rationale: So that the doors are capable of being opened outwards from the outside, in case of emergency, in the case where someone has fallen against the door and is unable to get up;
- (i) doors to accessible sanitary facilities should comply with the guidance on internal doors in 1.3 however although the effective door width should be as wide as possible 1.3.3.2 (b) and (c) do not apply to standard cubicles or cubicles for ambulant disabled people;
- (j) the fire alarm should emit a visual and audible signal.  
Rationale: To warn occupants with vision or hearing impairment;
- (k) the emergency assistance alarm system (where required, refer to Diagrams 15a, 15b, 16, 21, 22, 23, 24 and 25) should have:
  - (i) a pull cord reachable from a wheelchair and the WC, the shower or bath, or from the floor if someone has fallen, in some cases two pull chords may be required (refer to 1.5.6 (e));
  - (ii) visual and audible indicators to confirm that an emergency call has been activated;
  - (iii) a reset control reachable from a wheelchair and the WC, in case a false alarm is raised;
  - (iv) a warning signal that is distinguishable visually and audibly from the fire alarm;
  - (v) a visual and audible indicator should be provided outside the room where it can be easily seen and heard by people able to give assistance and also at a central control point;
- (l) all lighting controls should comply with the guidance for switches and controls (refer to 1.5.6);
- (m) the general lighting level in sanitary facilities should be between 200 to 300 lux measured at floor level (refer to 1.6.5);
- (n) any heat emitters should either be screened or have their exposed surfaces kept at a temperature below 43° Celsius;
- (o) the floor surfaces should be firm, level and slip resistant when wet and dry. Guidance on slip resistance is given on BS 8300:2009 Annex E;

## Section 1.4

### Sanitary facilities for buildings other than dwellings

---

- (p) the surface finish of sanitary fittings, grab rails and doors, should contrast visually with their background. There should also be a visual contrast between wall and floor finishes (refer to 1.6.4);
- (q) a shelf should be provided for a bag, a briefcase or other personal belongings. Two clothes hooks should be provided, one at a level of 1050 mm and 1400 mm above floor level.  
Rationale: This avoids a person having to place belongings on the floor;
- (r) accessible sanitary facilities should not be located in a way that compromises the privacy of users. However, the provision of lobbies to accessible sanitary facilities should be avoided where possible as lobby doors may create barriers to easy movement;
- (s) the WC pan should conform to I.S. EN 997:2003 in terms of key dimensions, in order to accommodate the use of variable height toilet seat risers.  
Rationale: This will facilitate people who find it difficult to use the standard seat height;
- (t) a colostomy changing surface should be provided in all accessible WCs. Where high/low level cisterns are used (incorporating a rail with a padded back rest) a separate colostomy changing shelf 125 mm to 150 mm deep x 400 mm wide (min), with its surface 950 mm (max) above floor level should be provided. Where a flat topped close-coupled cistern is used the flat topped cistern should be adequate to provide a colostomy changing surface for standing users without the extra requirement for a separate shelf;
- (u) the activation of a manual flush mechanism should be clearly visible, easy to use and require little strength and no fine hand movements. TGD G should be referred to for guidance on efficient use of water for flushing. Spatula-shaped WC flush handles are suitable for people with a wide range of abilities and can be activated with an elbow or fist;
- (v) where automatic flushing is provided it should be clearly indicated;
- (w) where the activator for the flush mechanism is to one side, it should be positioned on the open or transfer side of the WC, ensuring it can be reached by a person who has transferred back into a wheelchair;
- (x) the wall construction and fixings used to support grab rails should be capable of resisting the load exerted by users when pulling themselves to a standing or upright position.

# Section 1.4

## Sanitary facilities for buildings other than dwellings

---

### 1.4.5 Wheelchair accessible unisex WC

In addition to the general guidance in 1.4.4 where a wheelchair accessible unisex WC is provided:

(a) the minimum overall dimensions and arrangement of fittings within a wheelchair accessible unisex WC should comply with Diagram 15a or 15b, 16 and 17. Room dimensions of 1800 mm x 2500 mm are based on an 1800 mm x 1800 mm turning space, while room dimensions of 1500 mm x 2200 mm provide for a 1500 mm x 1500 mm turning space in small buildings as defined in 1.4.3.1;

(b) where there is only one WC provided in a building, a standing user height wash basin should be provided in addition to the finger rinse basin. The overall width of the room should be increased from 1800 mm to 2300 mm (or from 1500 mm to 2000 mm for a 1500 mm x 1500 mm turning space). The washbasin should not impinge on the wheelchair turning space and the rim of the washbasin should be between 780 mm to 800 mm (refer to Diagram 17).

Rationale: This provision will facilitate the needs of a wider range of users;

(c) the door should be on the wall opposite the WC, on the same side of the room as the transfer space, as illustrated in Diagram 15a;

(d) a distance of 750 mm should be provided from the back wall to the front of the WC pan.

Rationale: This allows the wheelchair seat to be parallel with the toilet seat, so that the wheelchair can be reversed against the wall and the person using the toilet does not have to manoeuvre both sideways and also backwards to transfer to and from the WC pan;

(e) the distance between the front of the WC pan and the nearest edge of the finger rinse basin should be between 140 mm and 160 mm.

Rationale: The user should be able to, from a sitting position on the WC, lean forward, wash hands in the finger rinse basin and insert or take out the basins waste plug before transferring back to the wheelchair;

(f) grab rails should be a minimum of 600 mm in length and should contrast visually with the supporting background surface (refer to 1.6.4);

(g) an emergency assistance alarm system should be provided in accordance with 1.4.4 (k);

(h) heat emitters, casings and shelves should be located so that they do not project into or restrict the minimum clear wheelchair manoeuvring space, nor the space beside the WC used for transfer from the wheelchair to the WC.

# Section 1.4

## Sanitary facilities for buildings other than dwellings

**Diagram 15a Wheelchair accessible unisex WC (1800 mm x 1800 mm turning space)**

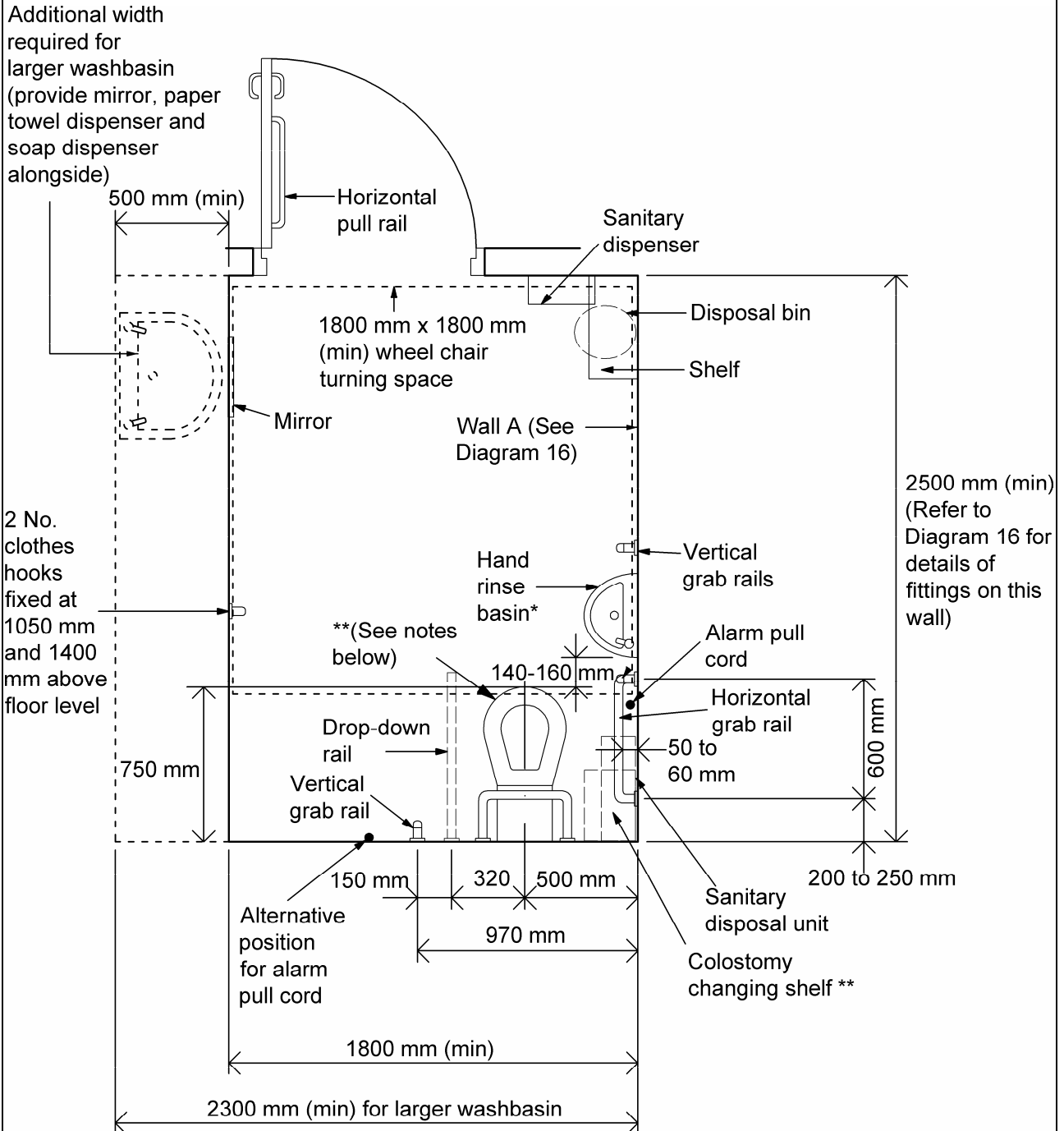

**NOTE:**

Example layout shown is for right-hand transfer to WC

The overall dimensions should exclude such items as heat emitters, skirting boards, tiles and boxing in of pipework. Adjustments in room sizes will be needed to accommodate these items.

\* The tap on the hand rinse basin should be positioned on the side closest to the WC

\*\* Where high or low level cisterns are used, a rail with a padded back rest and a separate colostomy changing shelf 125 mm to 150 mm deep x 400 mm (min) wide with its surface 950 mm above floor level should be provided. Where a flat topped close-coupled cistern is used, the cistern should be adequate to also act as a back rest. If the top of the cistern is flat it should be adequate to facilitate a colostomy changing surface for standing users without the extra requirement for a separate shelf.

# Section 1.4

## Sanitary facilities for buildings other than dwellings

**Diagram 15b Wheelchair accessible unisex WC (1500 mm x 1500 mm turning space)**

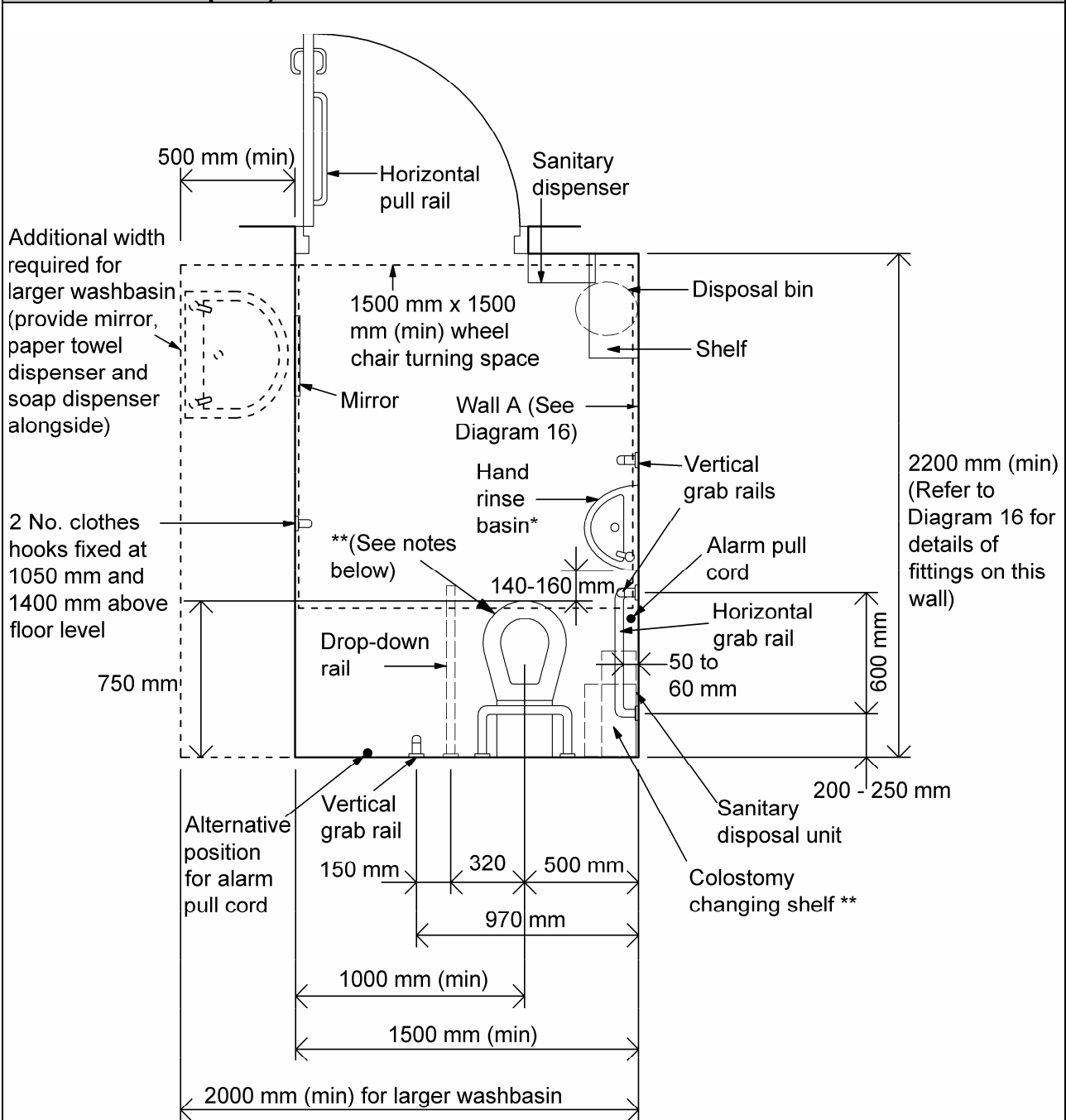

**NOTE:**

Example layout shown is for right-hand transfer to WC

The overall dimensions should exclude such items as heat emitters, skirting boards, tiles and boxing in of pipework. Adjustments in room sizes will be needed to accommodate these items.

\* The tap on the hand rinse basin should be positioned on the side closest to the WC

\*\* Where high or low level cisterns are used, a rail with a padded back rest and a separate colostomy changing shelf 125 mm to 150 mm deep x 400 mm (min) wide with its surface 950 mm above floor level should be provided. Where a flat topped close-coupled cistern is used, the cistern should be adequate to also act as a back rest. If the top of the cistern is flat it should be adequate to facilitate a colostomy changing surface for standing users without the extra requirement for a separate shelf.

# Section 1.4

## Sanitary facilities for buildings other than dwellings

**Diagram 16 Heights of various fittings on Wall A of a wheelchair accessible unisex WC (refer to Diagram 15a or 15b)**

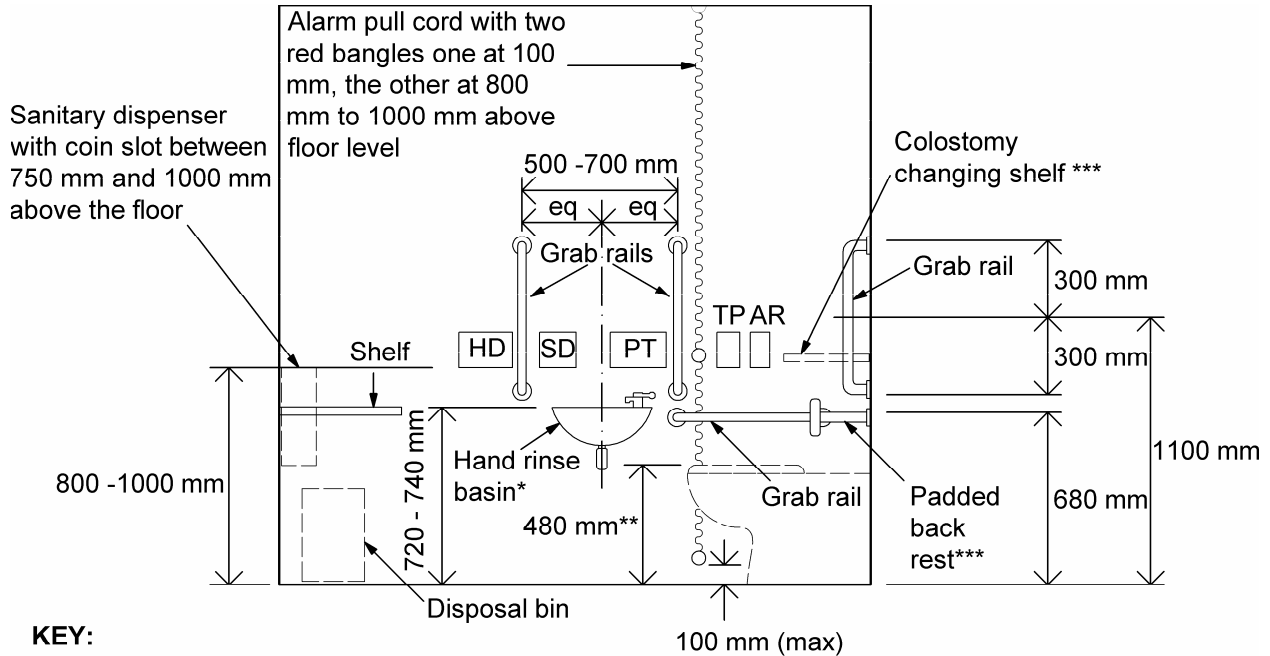

**KEY:**

- HD = Possible position for automatic hand dryer
- SD = Soap dispenser
- PT = Paper towel dispenser
- TP = Toilet paper dispenser
- AR = Alarm reset button

**NOTE:**

Height of drop-down rails to be the same as the other horizontal grab rails

\*The tap on the hand rinse basin should be positioned on the side closest to the WC

\*\*Height subject to manufacturing tolerance of WC pan

\*\*\* Where high or low level cisterns are used, a rail with a padded back rest and a separate colostomy changing shelf 125 mm to 150 mm deep x 400 mm (min) wide with its surface 950 mm above floor level should be provided. Where a flat topped close-coupled cistern is used, the cistern should be adequate to also act as a back rest. If the top of the cistern is flat it should be adequate to facilitate a colostomy changing surface for standing users without the extra requirement for a separate shelf.



# Section 1.4

## Sanitary facilities for buildings other than dwellings

**Diagram 17 Location of independent mirrors, accessories and washbasin**

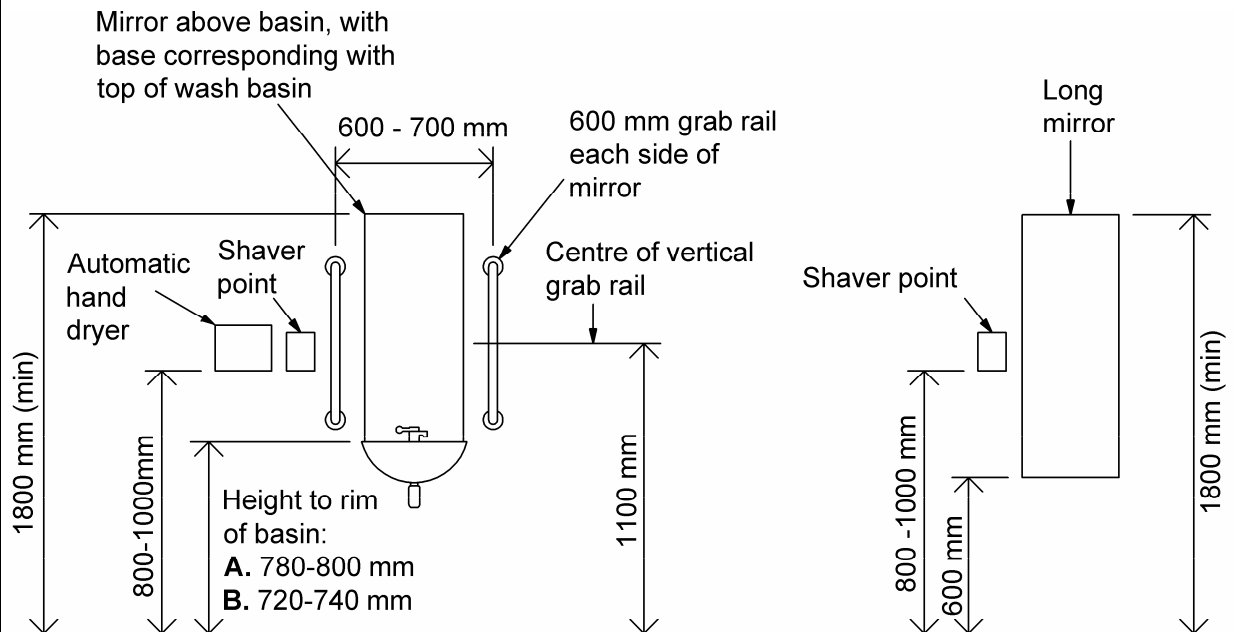

**a) In bathrooms and shower rooms**

Location of independent washbasin, mirror and grab rails (not associated with a corner WC), for wheelchair users and ambulant disabled people

- A. For ambulant disabled people only
- B. For both ambulant disabled people and wheelchair users

**b) In a unisex accessible WC**

Long mirror located away from washbasin suitable for wheelchair users and ambulant disabled people (mirror and associated fittings used within a unisex WC compartment or within a separate sex facility serving a range of compartments)

### 1.4.6 Cubicles

In addition to the general guidance in 1.4.4 further guidance is given below for cubicles.

#### 1.4.6.1 Standard cubicles

Where standard cubicles have inward opening doors there should be a minimum 450 mm diameter manoeuvring space provided between the swing of the door, the WC pan and the side wall of the compartment (refer to Diagram 18).

**Diagram 18 Standard WC cubicle**

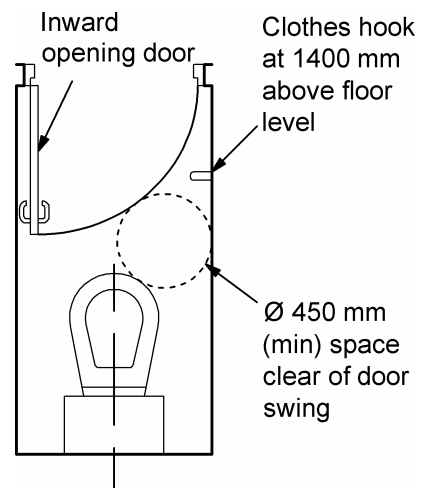

## Section 1.4

# Sanitary facilities for buildings other than dwellings

---

### 1.4.6.2 Cubicles for ambulant disabled people

For people using crutches or with other mobility impairment cubicles with a larger than standard clear activity or manoeuvring space and grab rails will be more accessible.

Where cubicles for ambulant disabled people are provided:

- (a) the width of the cubicle should be between 800 mm and 900 mm;
- (b) the WC should be centrally located on the back wall;
- (c) an activity space of 750 mm (clear of the door swing) should be provided as per Diagram 19b);
- (d) a horizontal and vertical grab rail should be provided either side to the WC pan;
- (e) a colostomy changing surface should be provided. Where high/low level cisterns are used (incorporating a rail with a padded back rest) a separate colostomy changing shelf 125 mm to 150 mm deep x 400 mm wide (min), with its surface 950 mm (max) above floor level should be provided. Where a flat topped close-coupled cistern is used the flat topped cistern should be adequate to provide a colostomy changing surface for standing users without the extra requirement for a separate shelf;
- (f) the minimum dimensions and arrangement of the cubicle, activity space, grab rails and other fittings should be provided in accordance with Diagram 19a) and b).

### 1.4.6.3 Enlarged cubicles

Cubicles with extra space will be more accessible for a range of people including parents with children, people carrying luggage, ambulant disabled people and people with assistance dogs.

Where enlarged cubicles are provided:

- (a) the minimum width of the cubicle should be 1200 mm;
- (b) the centreline of the WC should be between 450 mm and 500 mm from one wall;
- (c) an activity space of 750 mm (clear of the door swing) should be provided as per Diagram 19c);
- (d) a horizontal and vertical grab rail should be provided adjacent to the WC pan;
- (e) a vertical grab rail should be provided on the rear wall adjacent to the side of the cistern furthest away from the wall with the horizontal grab rail);
- (f) a colostomy changing surface should be provided. Where high/low level cisterns are used (incorporating a rail with a padded back rest) a separate colostomy changing shelf 125 mm to 150 mm deep x 400 mm wide (min), with its surface 950 mm (max) above floor level should be provided. Where a flat topped close-coupled cistern is used the flat topped cistern should be adequate to provide a colostomy changing surface for standing users without the extra requirement for a separate shelf.

# Section 1.4 Sanitary facilities for buildings other than dwellings

**Diagram 19 WC cubicle for ambulant disabled people and enlarged cubicle**

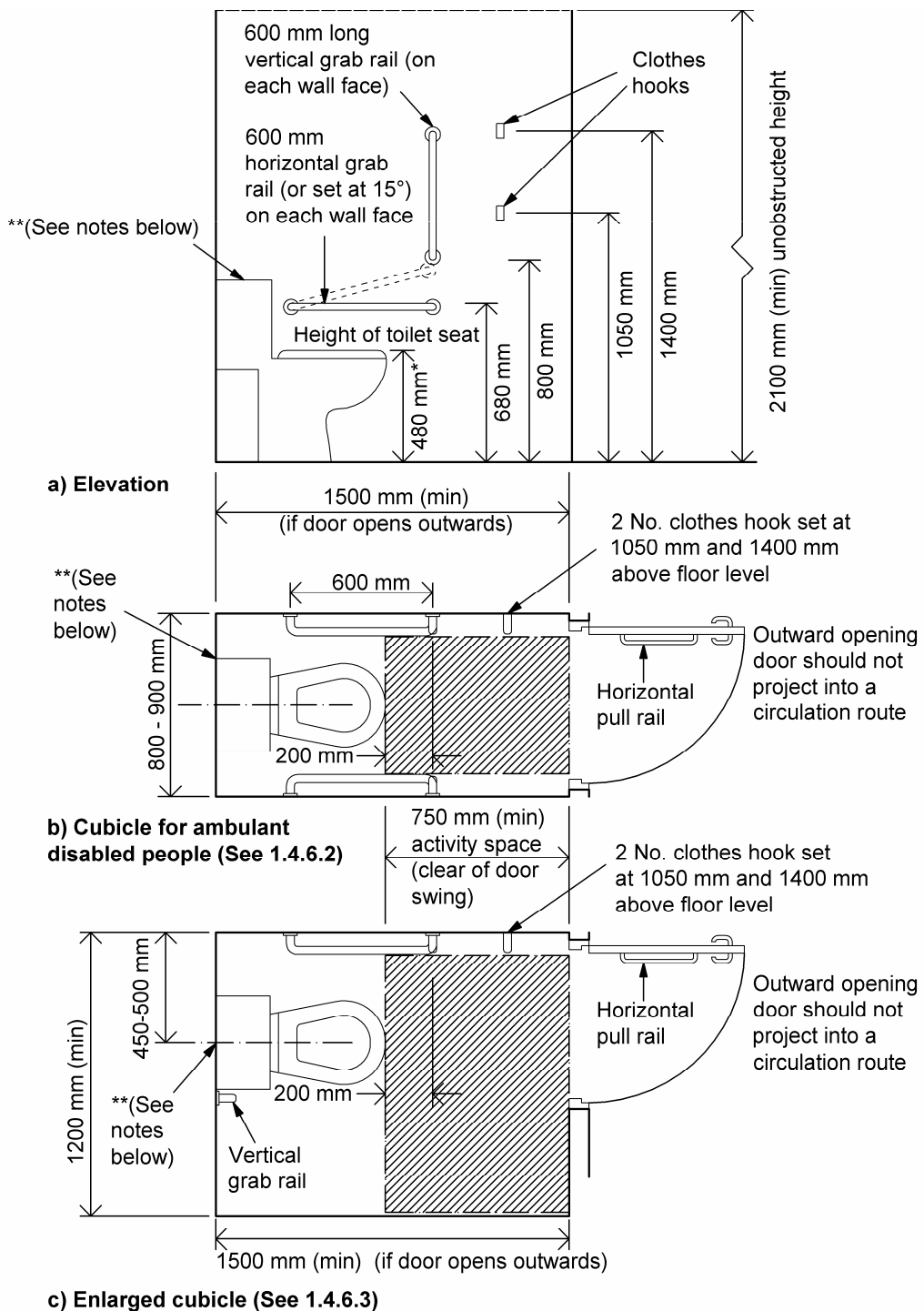

**NOTE:**

\*Height subject to manufacturing tolerance of WC pan

\*\*Where high or low level cisterns are used, a rail with a padded back rest and a separate colostomy changing shelf 125 mm to 150 mm deep x 400 mm (min) wide with its surface 950 mm above floor level should be provided. Where a flat topped close-coupled cistern is used, the cistern should be adequate to also act as a back rest. If the top of the cistern is flat it should be adequate to facilitate a colostomy changing surface for standing users without the extra requirement for a separate shelf.

The overall dimensions should exclude such items as heat emitters, skirting boards, tiles and boxing in of pipework. Adjustments in room sizes will be needed to accommodate these items.

## Section 1.4

# Sanitary facilities for buildings other than dwellings

---

### 1.4.7 Accessible urinals

**In addition to the general guidance in**

**1.4.4** where accessible urinals are provided:

- (a) a clear area of 900 mm x 1400 mm in front of the wheelchair accessible urinal should be level;
- (b) the rim of the wheelchair accessible urinal should be 380 mm above floor level, for ambulant disabled people the standard 500 mm is adequate, as per Diagram 20;
- (c) vertical grab rails should be provided on both sides of the urinal. To support a person who is standing they should be 600 mm long, for a wheelchair user they should be 900 mm long to provide support in a sitting or standing position. The top fixings for both handrails should be 1400 mm above floor level as per Diagram 20;
- (d) urinals and grab rails should contrast visually with the wall on which they are attached (refer to 1.6.4);
- (e) where wash basins are provided, at least one wash basin with its rim set at between 720 mm and 740 mm above the floor level should be provided. Knee space under the basin should be free of obstructions and should not have a pedestal to allow a wheelchair user to pull up close to the basin.

# Section 1.4

## Sanitary facilities for buildings other than dwellings

**Diagram 20 Accessible urinals**

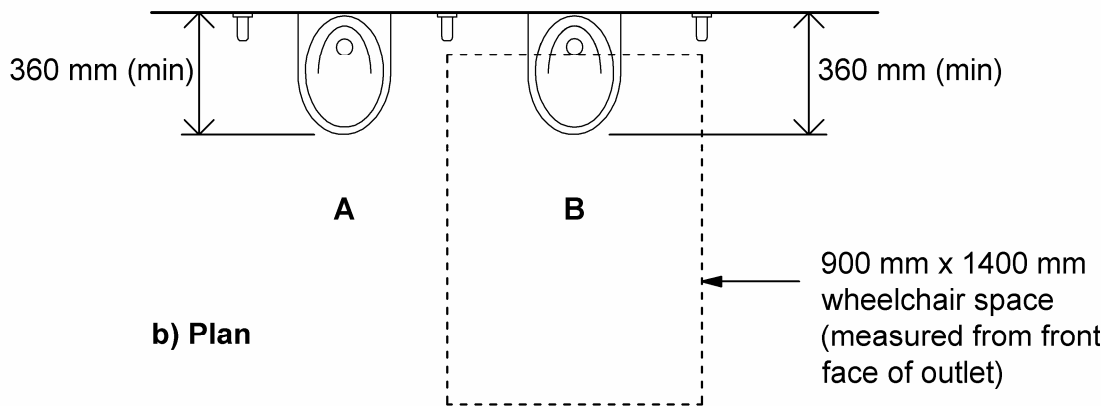
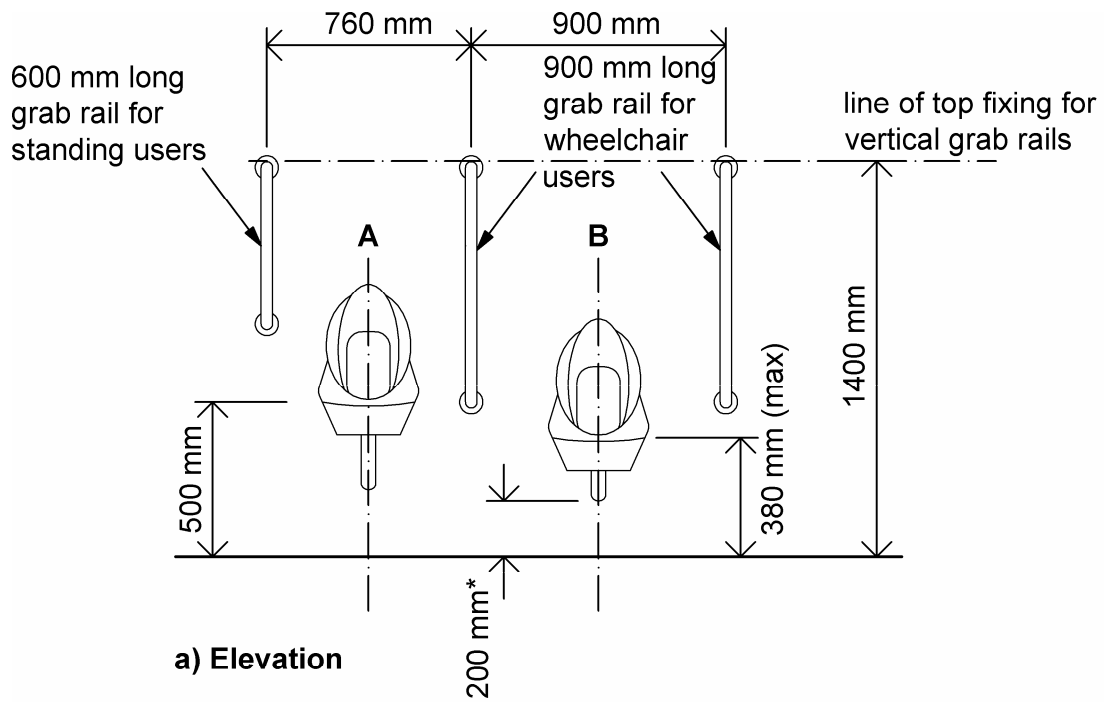

**A** = Suitable for ambulant disabled people  
**B** = Suitable for wheelchair users

**NOTE:** Wall space kept free of pipework to 200 mm above floor level unless urinal projects more than the minimum 360 mm from the wall

# Section 1.4

## Sanitary facilities for buildings other than dwellings

---

### 1.4.8 Accessible bathrooms/shower rooms

some from the WC;

**In addition to the general guidance in 1.4.4** where wheelchair accessible en-suite bathrooms or shower rooms are provided:

- (a) an en-suite shower room should be in accordance with Diagram 21;
- (b) wall mounted drop down support rails and a wall mounted slip resistant tip-up seat should be provided in the shower area;
- (c) an en-suite bathroom with WC for independent use should be in accordance Diagram 22 and 23;
- (d) the bath should be provided with a transfer seat, 400 mm deep and equal to the width of the bath;
- (e) the WC and washbasin should be similar to the corner arrangement WC for a unisex accessible toilet, except the washbasin is larger and set back from the sidewall.  
Rationale: So as not to project into the transfer space in front of the WC;
- (f) the washbasin should be approximately 500 mm wide x 450 mm deep with a rim height set between 720 mm and 740 mm above the floor level.  
Rationale: The larger washbasin enables people to have a full body-wash or to wash personal care equipment;
- (h) the washbasin should have a waste plug.  
Rationale: This enables the basin to be filled prior to using the WC, as the taps may be out of reach for

- (i) knee space under the basin should be free of obstructions.  
Rationale: This allows a wheelchair to pull up close to the basin;
- (j) the shower controls should be easy to use and capable of being operated with a closed fist e.g. with a lever handle operation.

# Section 1.4

## Sanitary facilities for buildings other than dwellings

**Diagram 21 An example of a shower room incorporating a corner WC for independent use**

**NOTE:**

Horizontal grab rails, WC fittings, shower curtain/enclosure rail and towel rail not shown for clarity. Fixing height of horizontal rails to be the same as drop down rails.

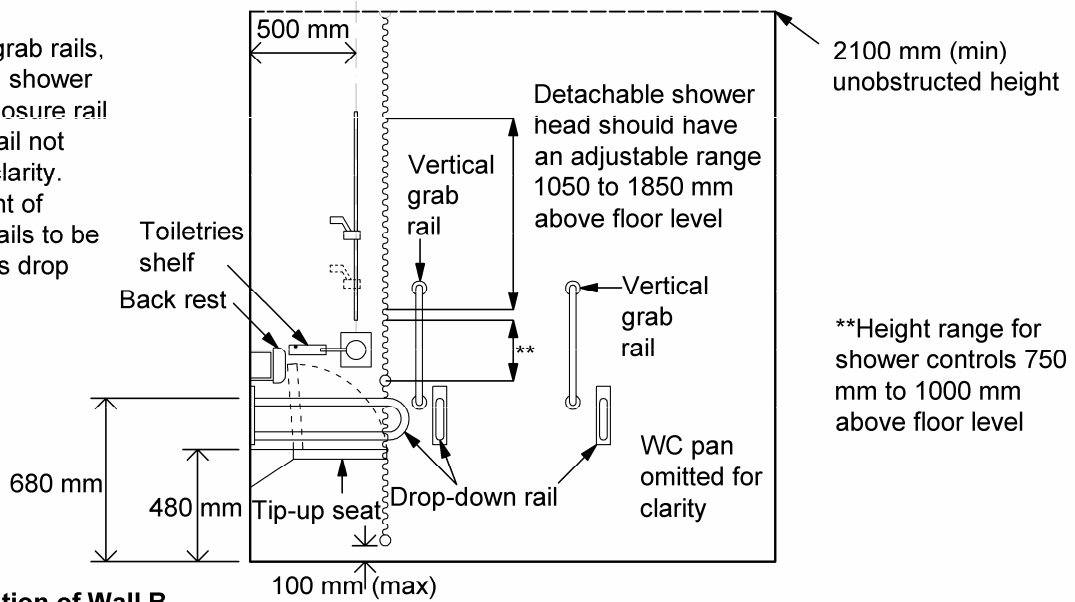

**a) Elevation of Wall B**

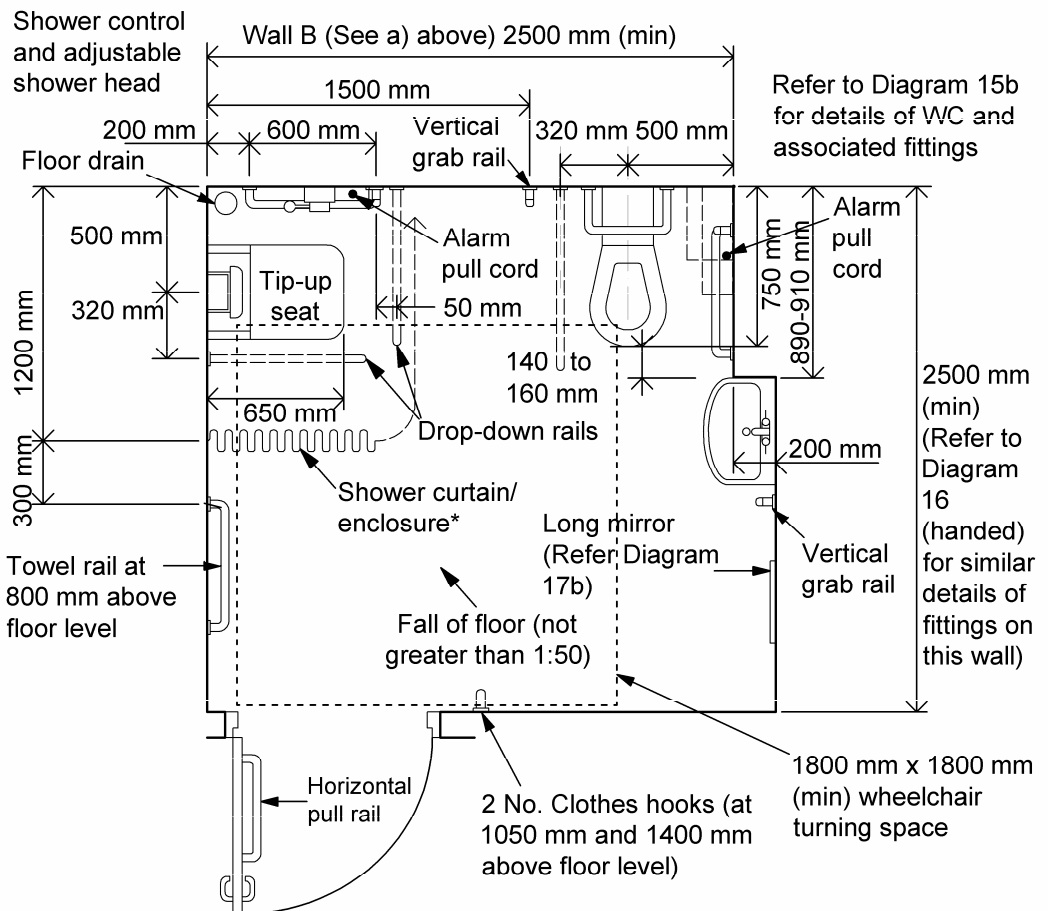

**b) Plan**

**NOTE:**

Example layout shown is for left-hand transfer to WC and shower seat.

The overall dimensions should exclude such items as heat emitters, skirting boards, tiles and boxing in of pipework. Adjustments in room sizes will be needed to accommodate these items.

\*A shower enclosure should be easy to use and not impinge on the transfer or turning space when fully open.

# Section 1.4

## Sanitary facilities for buildings other than dwellings

**Diagram 22 An example of a bathroom for independent use incorporating a corner WC layout**

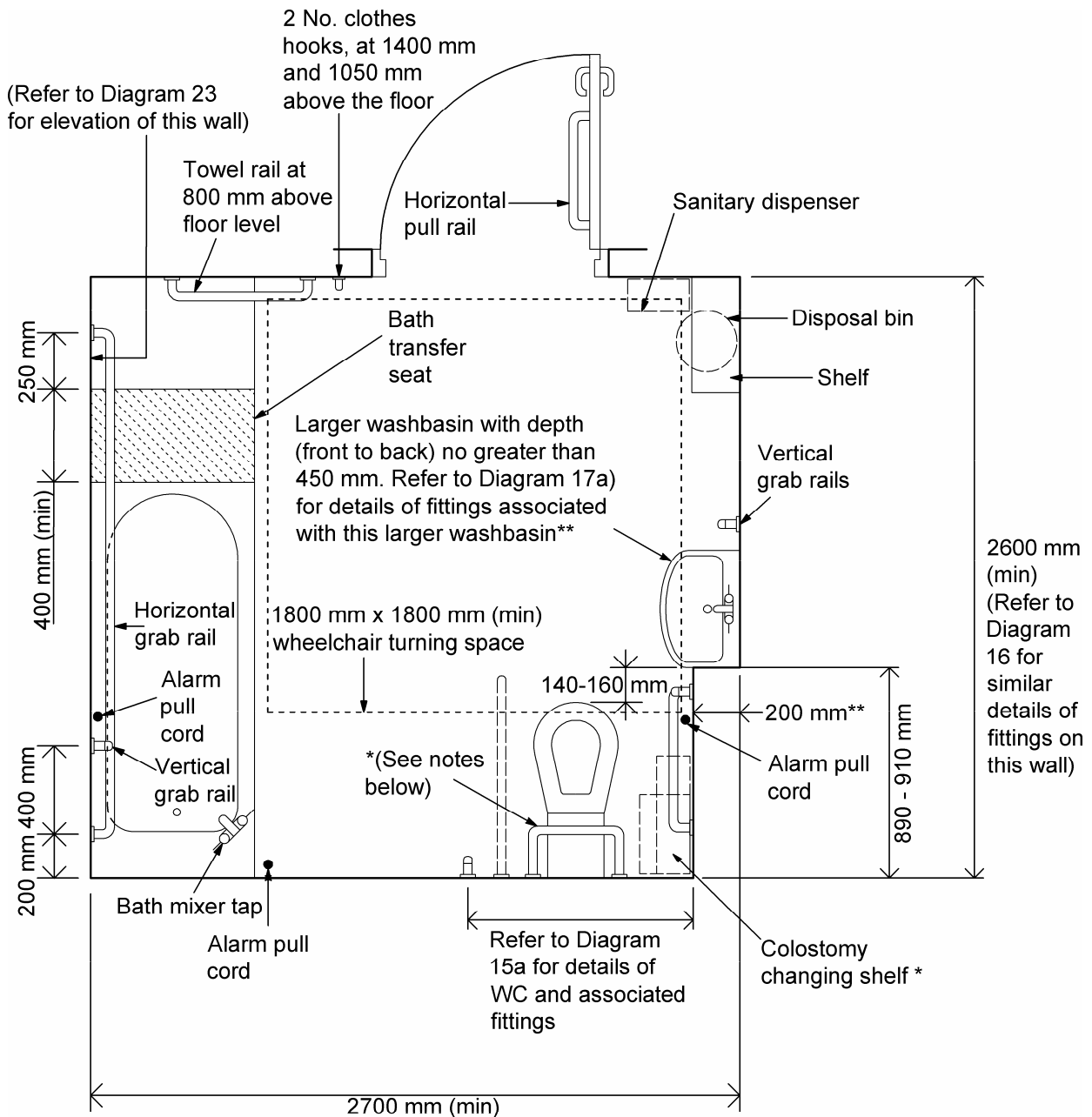

**NOTE:**

Example layout shown is for right-hand transfer to WC

The overall dimensions should exclude such items as heat emitters, radiators, skirting boards, tiles and boxing in of pipework. Adjustments in room sizes will be needed to accommodate these items.

\* Where high or low level cisterns are used, a rail with a padded back rest and a separate colostomy changing shelf 125 mm to 150 mm deep x 400 mm (min) wide with its surface 950 mm above floor level should be provided. Where a flat topped close-coupled cistern is used, the cistern should be adequate to also act as a back rest. If the top of the cistern is flat it should be adequate to facilitate a colostomy changing surface for standing users without the extra requirement for a separate shelf.

\*\*200 mm wall recess required with 450 mm deep washbasin to facilitate frontal transfer to WC



# Section 1.4

## Sanitary facilities for buildings other than dwellings

**Diagram 23 Grab rails and fittings associated with a bath (refer to Diagram 22)**

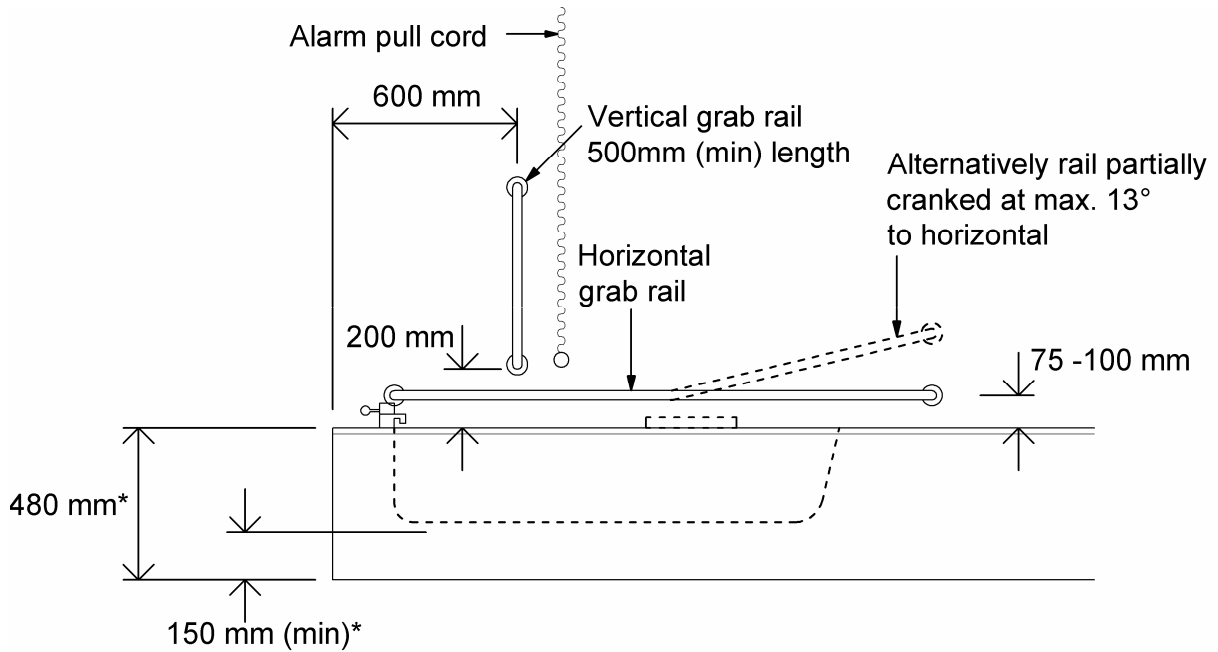

**a) Elevation**

**NOTE:**

\* To meet both these criteria, a shallower than normal bath may be necessary

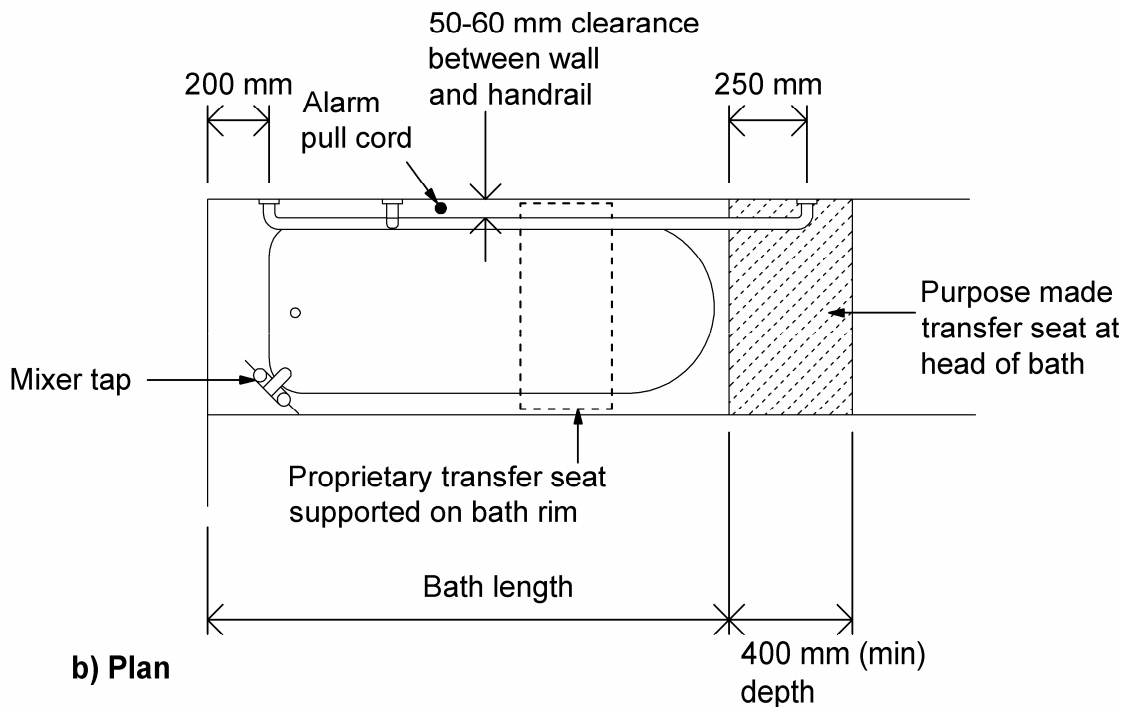

**b) Plan**

## Section 1.4

# Sanitary facilities for buildings other than dwellings

---

### 1.4.9 Changing and/or showering facilities

#### 1.4.9.1 Changing facilities

**In addition to the general guidance in 1.4.4** where changing facilities are provided:

- (a) the overall dimensions and the arrangement of equipment and controls for an individual self contained unit should comply with Diagram 24;
- (b) the floor should be level, and a manoeuvring space 1500 mm deep should be provided in front of any lockers provided in communal areas;
- (c) a choice of layouts suitable for left-hand and right-hand transfer should be provided when more than one changing and or showering facility is provided.

#### 1.4.9.2 Showering facilities

**In addition to the general guidance in 1.4.4** where showering facilities are provided:

- (a) the minimum dimensions and arrangement of fittings, etc, should be in accordance with Diagram 25;
- (b) the shower curtain/ enclosure should be operable from the shower seat. This should enclose the seat (when in a horizontal position) and grab rails;
- (c) a shelf, for toiletries etc, should be positioned so that it can be reached from the shower seat or from the wheelchair before or after transfer;
- (d) the floor should be self draining;
- (e) the markings on the shower control should be logical and clear;
- (f) the shower controls should be easy to use and capable of being operated with a closed fist e.g. with a lever handle operation.

# Section 1.4 Sanitary facilities for buildings other than dwellings

**Diagram 24 An example of a self-contained changing room for independent use**

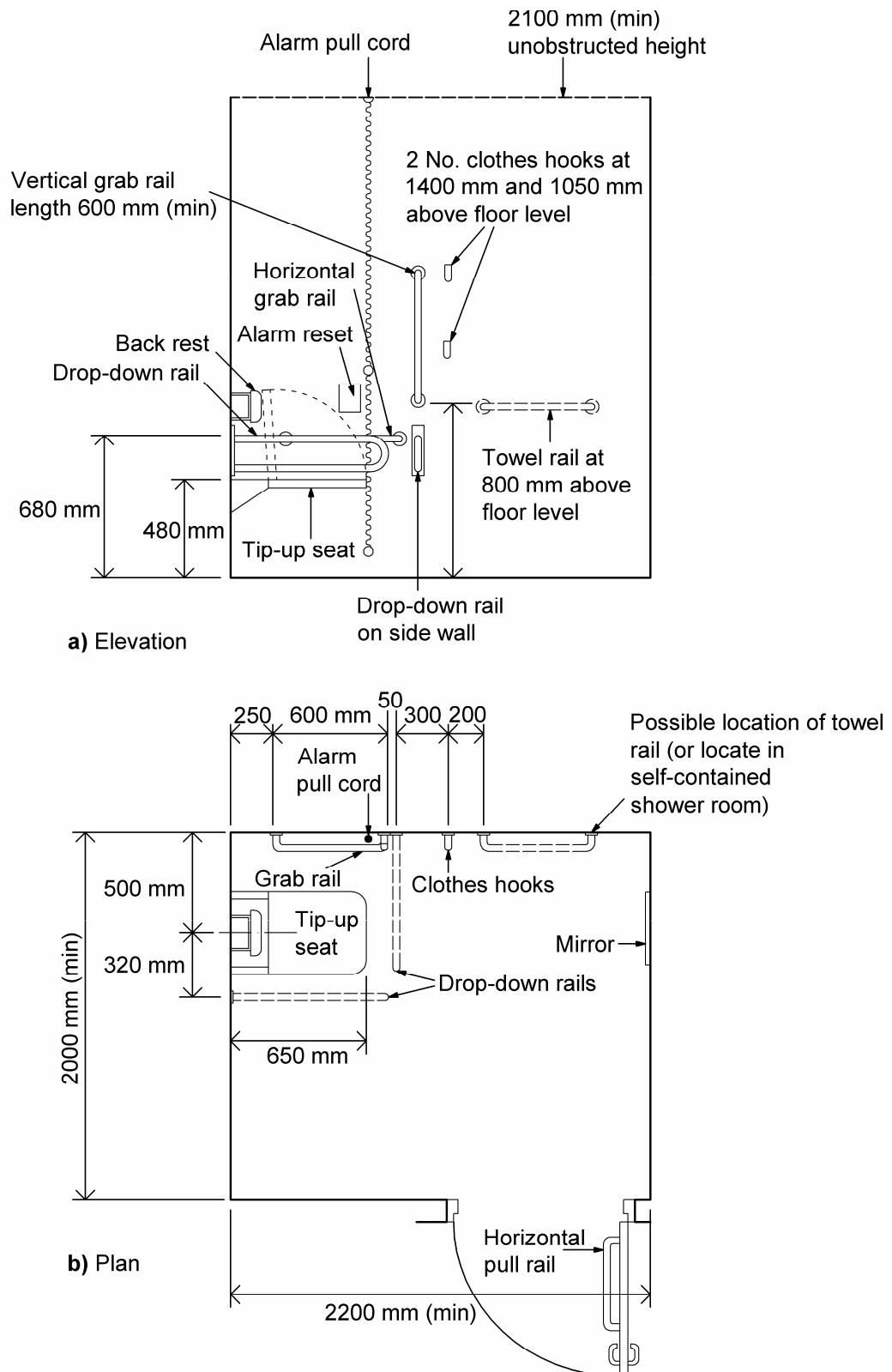

**NOTE:**

Example layout shown is for left-hand transfer to changing seat. The overall dimensions should exclude such items as heat emitters, radiators, skirting boards, tiles and boxing in of pipework. Adjustments in room sizes will be needed to accommodate these items.

# Section 1.4

## Sanitary facilities for buildings other than dwellings

**Diagram 25 An example of a self-contained accessible shower and/ or changing room for independent use**

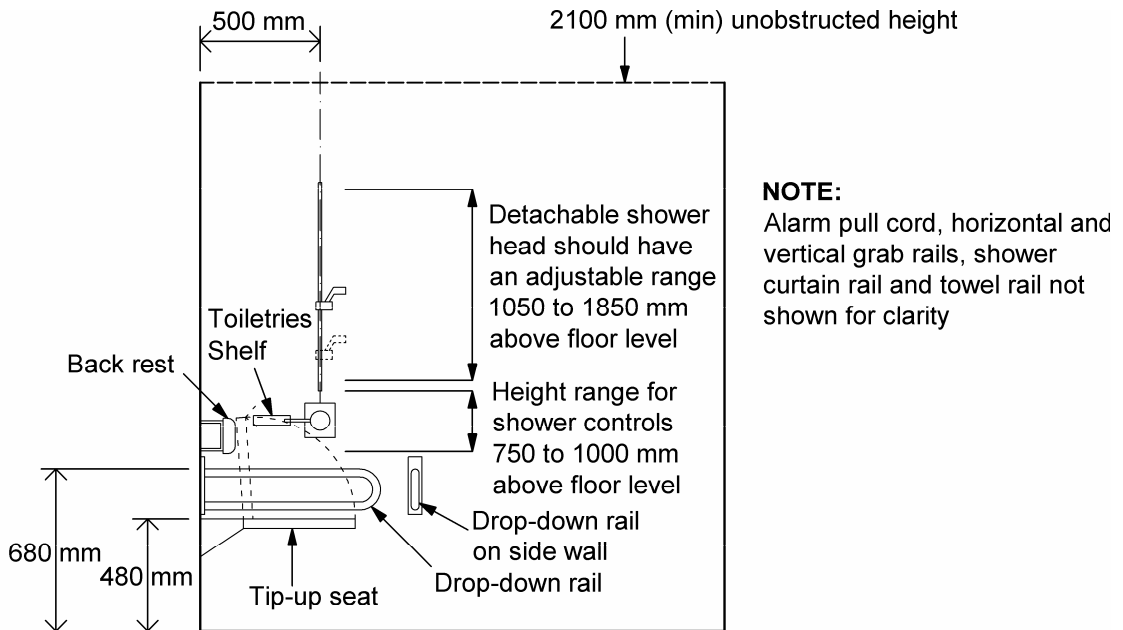

**a) Elevation**

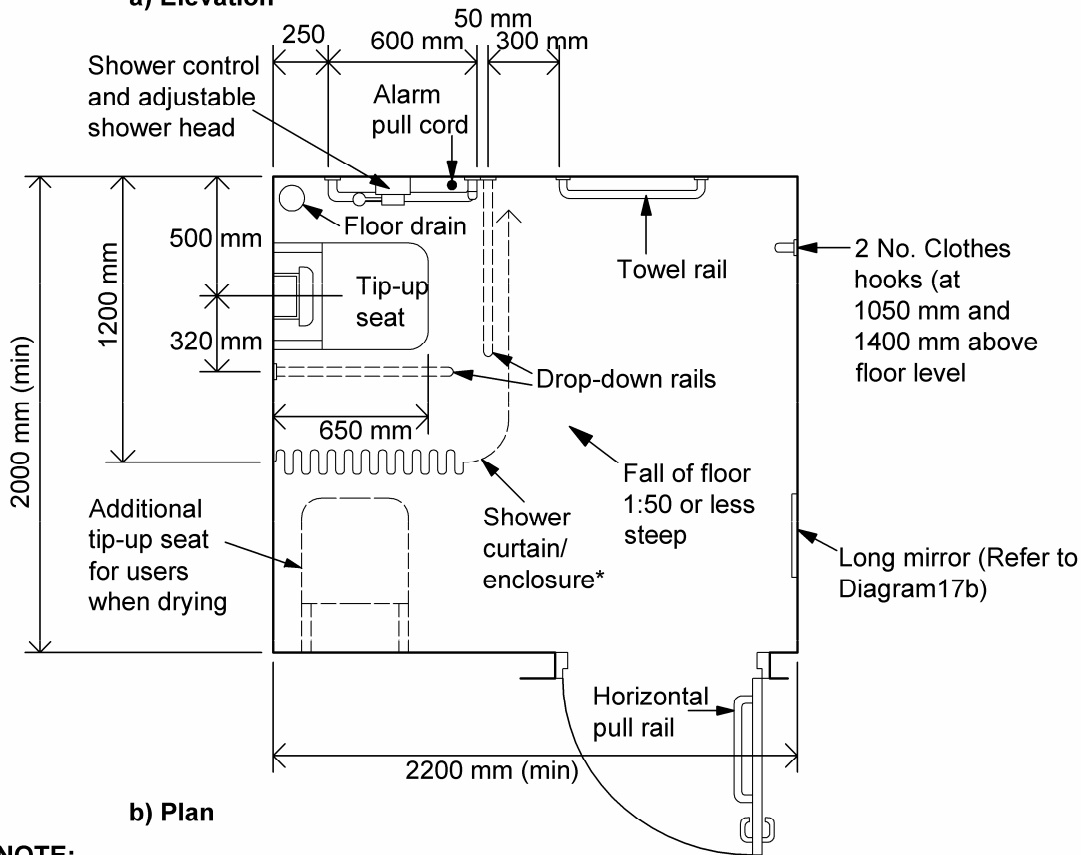

**b) Plan**

**NOTE:**

\* A shower enclosure should not impinge on the turning space when fully open.  
Example layout shown is for left-hand transfer to changing seat.  
The overall dimensions should exclude such items as heat emitters, radiators, skirting boards, tiles and boxing in of pipework. Adjustments in room sizes will be needed to accommodate these items.

# Section 1.5

## Other facilities in buildings other than dwellings

---

### Section 1.5 Other facilities in buildings other than dwellings

#### 1.5.1 Objective

**The objective is to ensure that all facilities within a building are accessible to and useable and that they are designed and constructed to facilitate active participation where appropriate.**

#### 1.5.2 Introduction

Provisions should be made to ensure facilities within a building are accessible for people (both visitors and staff) with a wide range of abilities, e.g. people with vision or hearing impairment, people with intellectual disabilities, people with mental impairment, ambulant disabled people, wheelchair users and people with small children (in buggies).

Guidance is given in this section on the features and characteristics of the following facilities to make them accessible to and useable for people with a wide range of abilities:

- (i) Audience and spectator facilities with fixed seating;
- (ii) Audience and spectator facilities without fixed seating;
- (iii) Refreshment facilities;
- (iv) Accessible sleeping accommodation;
- (v) Switches, outlets and controls

Audience and spectator facilities with fixed seating may be provided in several different types of buildings such as lecture/conference facilities in hotels or

offices, educational buildings, entertainment facilities in theatres, cinemas, sports facilities in stadia and sports centres.

Often, it is a functional characteristic of these types of buildings that audience or spectator facilities with fixed seating is provided at several levels and frequently this necessitates the use of tiered or raking floors. While ambulant disabled people should have access to all such levels, people using wheelchairs, notwithstanding the requirements for lifts, in Section 1.3, should have independent access to sufficient wheelchair spaces in areas which afford good viewing conditions. Wheelchair seating should be designed so that the spectators in wheelchairs can still see the event when other spectators are standing. Facilities that are available to other users of the premises, such as bars, WCs, etc, should also be accessible from these areas.

The minimum number of permanent and removable spaces should be in accordance with Table 3. Where a building contains several auditoria, e.g. a multi-screen cinema or a block of lecture theatres the minimum requirement in Table 3 applies to each auditorium.

Audience and spectator facilities without fixed seating may be provided in buildings such as lecture/conference facilities in hotels or offices, educational buildings, entertainment facilities in theatres, cinemas, sports facilities in stadia and sports centres. These facilities should be accessible in accordance with 1.5.4.

Refreshment facilities e.g. restaurants, bars and shared self service canteens should be so designed and constructed

# Section 1.5

## Other facilities in buildings other than dwellings

that they can be accessed and used by all (visitors and staff) independently or with companions.

Where sleeping accommodation is provided adequate provision should be made for people with a wide range of abilities. One guest bedroom out of every twenty, or a minimum of one guest bedroom if less than twenty guest bedrooms are provided should be suitable in terms of size, layout and

facilities for independent use by people with a wide range of abilities in accordance with 1.5.6. The same proportion of such bedrooms should have en-suite sanitary facilities as provided in other bedrooms. For guidance on sanitary facilities refer to Section 1.4.

Switches, outlets and controls for all facilities should be made easy to see; access and use by all (refer to 1.5.7).

<b>Table 3 Provision of wheelchair spaces in audience seating</b>		
<b>Seating capacity (persons)</b>	<b>Minimum provision of spaces for wheelchair users</b>	
	<b>Permanent seating</b>	<b>Removable seating</b>
Up to 600	1% of total seating capacity <sup>(i)</sup>	Remainder to make a total of 6 <sup>(i)</sup>
More than 600 but less than 10,000 <sup>(ii)</sup>	1% of total seating capacity <sup>(i)</sup>	Additional provision, if desired
<p><b>NOTE:</b></p> <p><sup>(i)</sup> Percentages need to be rounded up to determine the recommended number of spaces.</p> <p><sup>(ii)</sup> For seating capacities greater than 10,000 refer to guidelines given in 'Accessible stadia: a good practice guide to the design of facilities to meet the needs of disabled spectators and other users'.</p>		

### 1.5.3 Audience and spectator facilities with fixed seating

Where audience and spectator facilities with fixed seating are provided:

- (a) the route to the wheelchair spaces should be clearly signed;
- (b) the route to the wheelchair spaces should be accessible by wheelchair users, in accordance with Section 1.1;
- (c) at least one set of wheelchair spaces should be provided in pairs with standard seating on at least one side, to facilitate a friend or assistant and to avoid segregation. This can be provided on a permanent basis or created by removing a seat(s). Refer to Diagrams 26 and 27

(Alternative details are given in BS 8300:2009);

- (d) where more than two wheelchair spaces are provided, they should be located to give a range of un-obstructed views for the duration of the event (the view should not be obstructed by possible standing spectators) at each side, as well as at the front and back of the seating area.  
Rationale: This will help accommodate those with difficulty hearing or seeing on one side and those who need to be near lip readers or sign interpreters;
- (e) the clear space allowance for an occupied wheelchair in a parked

## Section 1.5

### Other facilities in buildings other than dwellings

---

position should be 900 mm x 1400 mm deep;

- (f) the floor of each wheelchair space should be level;
- (g) standard seats at the ends of rows and next to wheelchair spaces should have detachable or lift-up arms;
- (h) where wheelchair spaces are provided at the back of a stepped terraced floor, they should be provided in accordance with Diagram 27 (Alternative details are given in BS 8300:2009);
- (i) where a raised podium or stage is provided in a lecture/ conference facility, wheelchair users should have access to it by means of a ramp or lifting platform. Clear signage should be provided indicating its location (refer to 1.6.3);
- (j) stepped access routes to raked seating areas should have handrails where there is an adjacent wall. Rationale: Where steps lead to seating, a handrail is needed only on the wall side, so as not to obstruct access to the seating;
- (k) a hearing enhancement system in accordance with Section 1.6 should be provided for people with hearing impairment in all audience and spectator facilities;
- (l) rows and seats should be clearly numbered and well lit to assist people with vision impairment.

Further guidance on audience and spectator facilities is given in BS 8300:2009.

#### **1.5.4 Audience and spectator facilities without fixed seating**

Where audience and spectator facilities without fixed seating are provided:

- (a) where a raised podium or stage is provided in a lecture/ conference facility, wheelchair users should have access to it by means of a ramp or lifting platform. Clear signage should be provided indicating its location (refer to 1.6.3);
- (b) a hearing enhancement system in accordance with Section 1.6 should be provided for people with hearing impairment in all audience and spectator facilities. This does not include classrooms in primary and post primary schools or standard meeting rooms in offices.

## Section 1.5

### Other facilities in buildings other than dwellings

**Diagram 26** An example of wheelchair spaces in an audience and spectator facility with fixed seating

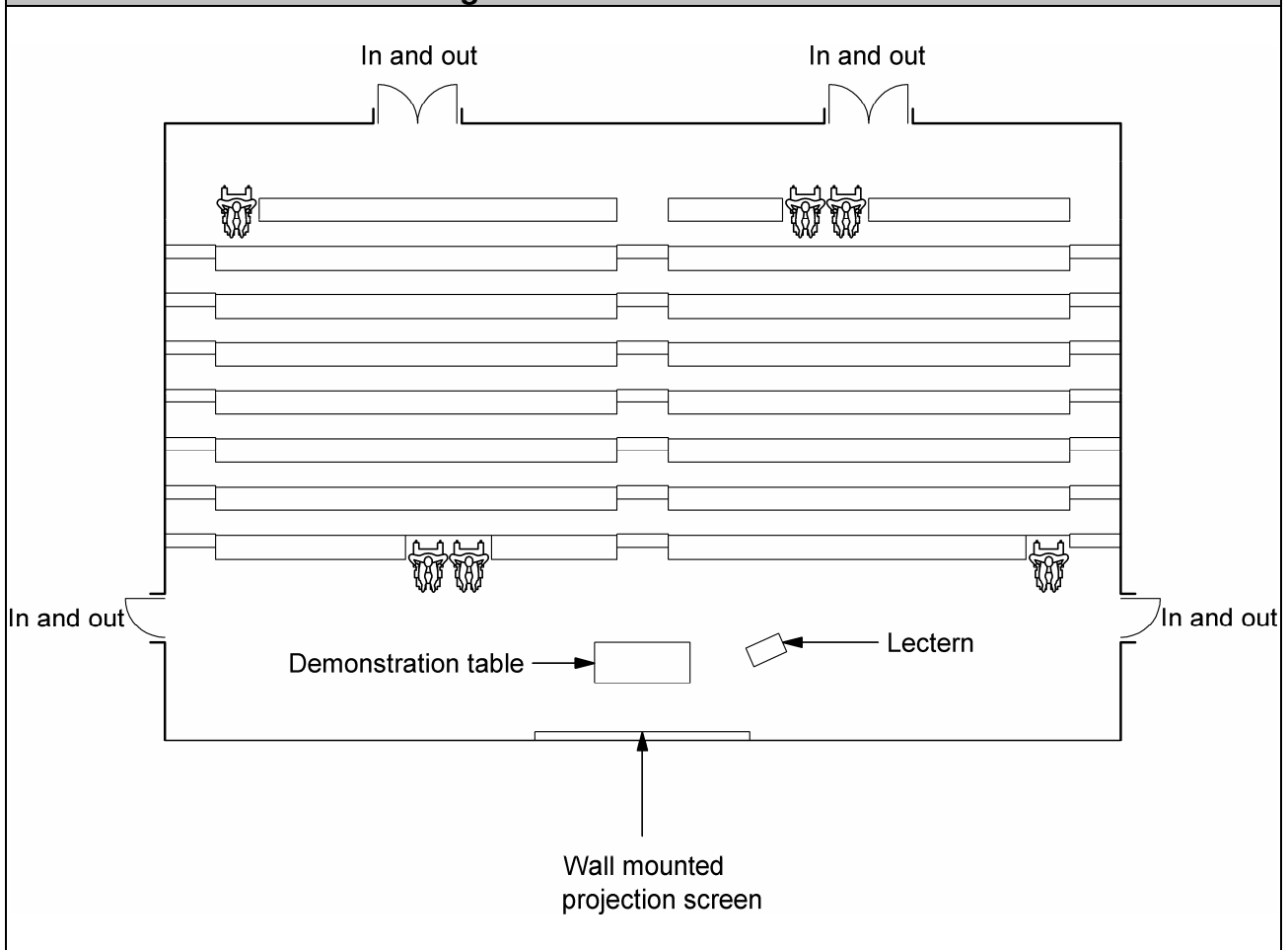



# Section 1.5

## Other facilities in buildings other than dwellings

**Diagram 27** An example of wheelchair space provision in an audience and spectator facility with fixed seating

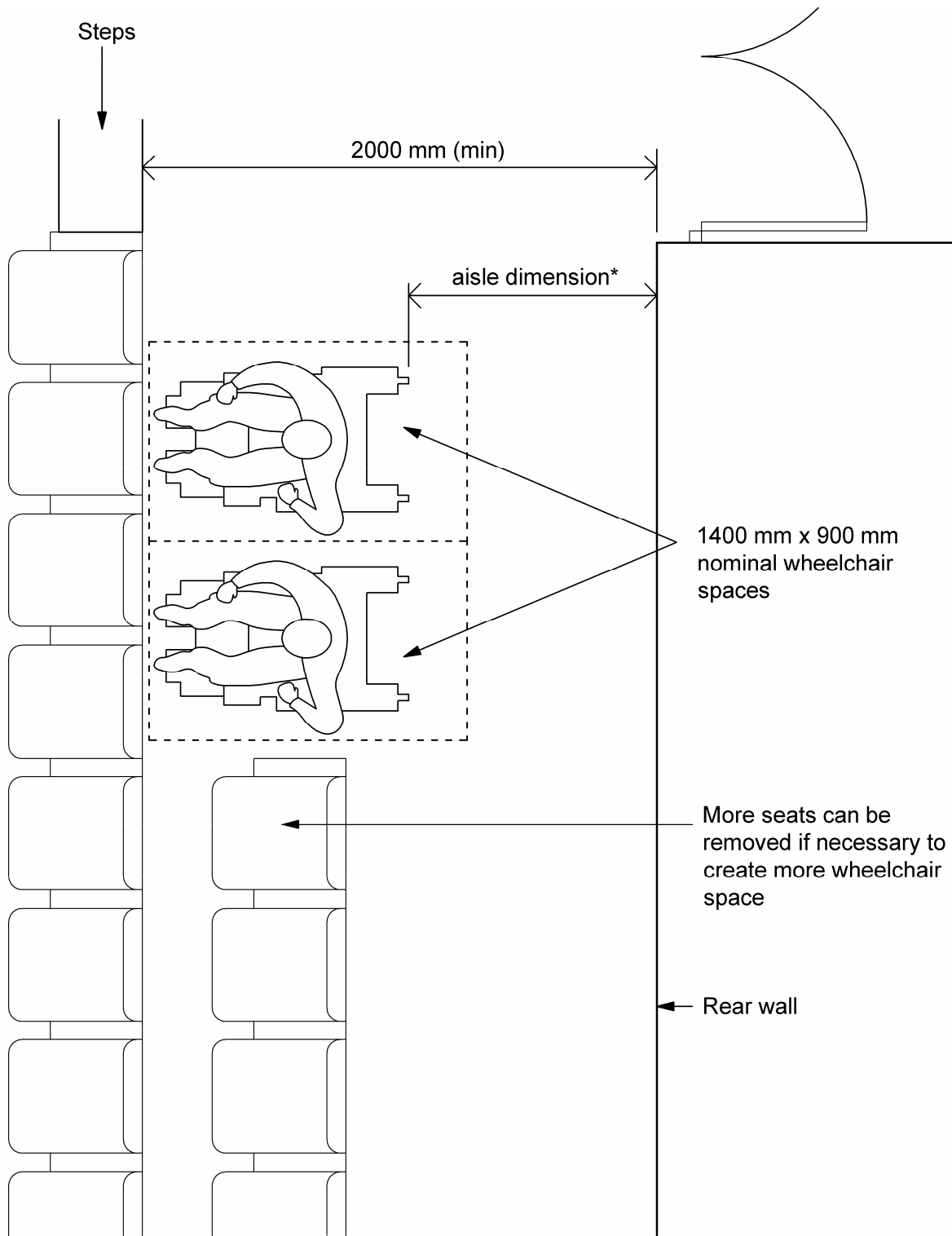

**Note:**

\* Refer to Part B/ TGD B for guidance on fire escape provisions

## Section 1.5

# Other facilities in buildings other than dwellings

---

### 1.5.5 Refreshment facilities

Where refreshment facilities are provided:

- (a) all users should have access to all parts of the facility. If there is a change in level, the different levels should be accessible (refer to 1.3);
- (b) in bars and restaurants a section of the working surface of a bar or serving counter 1500 mm long (min) should be permanently accessible to wheelchair users and at a level of not more than 850 mm above the floor;
- (c) a minimum clear manoeuvring space of 1800 mm x 1800 mm should be provided in front of a counter or bar, outside of any circulation route;
- (d) the worktop of a shared refreshment facility (e.g. a shared self service canteen) should be at a level of not more than 850 mm above the floor with a clear knee recess beneath the worktop to least 700 mm above the floor. The water taps should be accessible and either controlled automatically or capable of being operated with a closed fist. Refer to Diagram 28 for typical details;
- (e) routes to and from the refreshment facility from accessible seating, and other accessible facilities should also be accessible.

## Section 1.5

### Other facilities in buildings other than dwellings

**Diagram 28 Provision for a wheelchair user in a typical shared self service canteen**

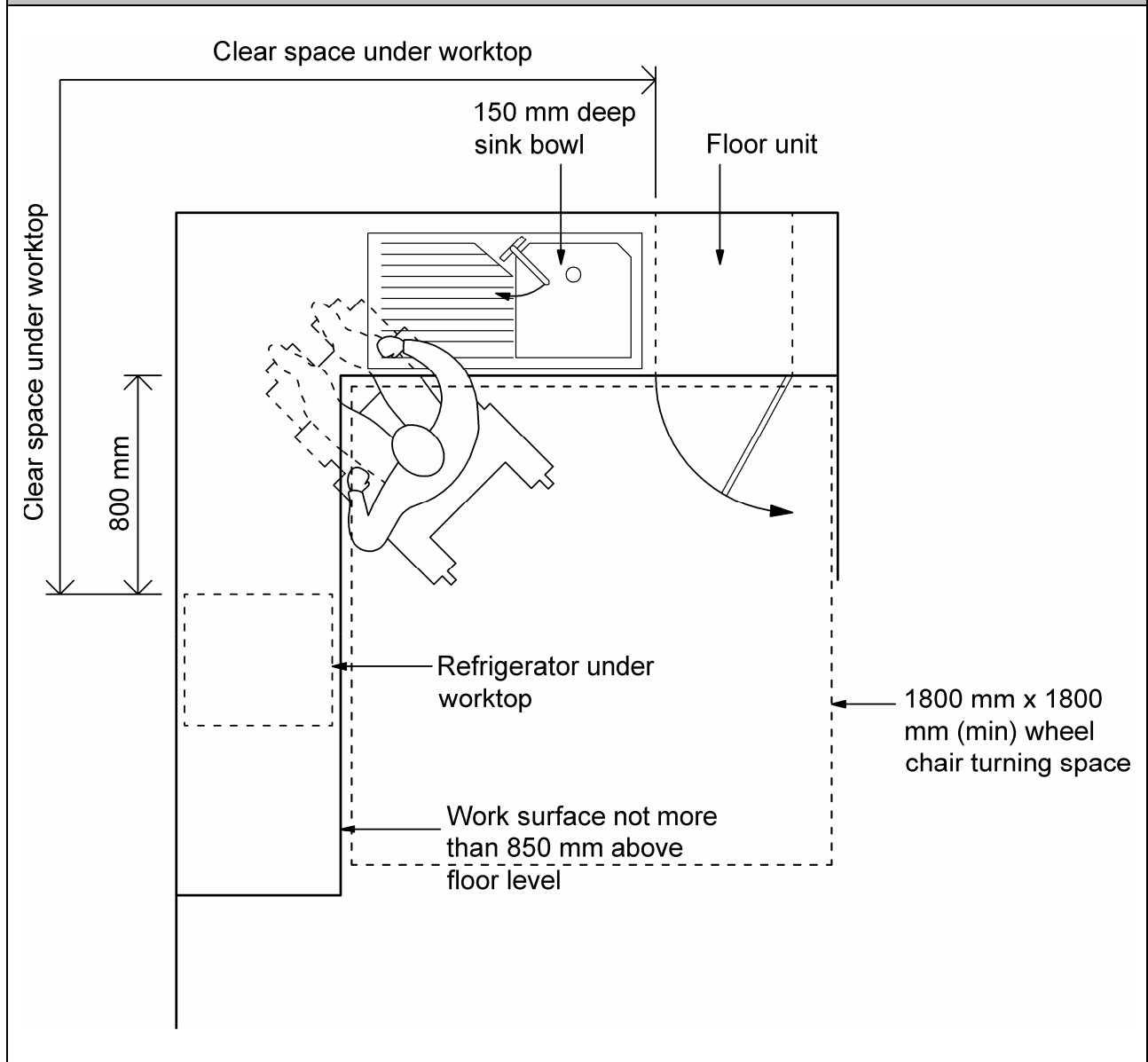

## Section 1.5

### Other facilities in buildings other than dwellings

---

#### 1.5.6 Accessible sleeping accommodation

Where accessible sleeping accommodation is provided:

- (a) the entrance door to the guest bedroom, should comply with the guidance in Section 1.3. The minimum effective clear opening width should be 800 mm;
- (b) swing doors where provided for built in wardrobes and other storage systems should open through 180°;
- (c) handles on hinged and sliding doors should be easy to grip and operate and contrast visually with the surface of the door (refer to 1.6.4);
- (d) openable windows and window controls should be located between 800 mm and 1000 mm above the floor and should be easy to operate without using both hands simultaneously;
- (e) it should have a visual fire alarm signal, in addition to the provisions for fire detection and alarm systems given in Part B/ TGD B;
- (f) a visual indicator should be provided within the accessible bedroom to alert an occupier with a hearing impairment that there is someone at the door;
- (g) bedroom numbers should be indicated in embossed characters and at a height of between 1200 mm and 1600 mm (max) above finished floor level;
- (h) accessible bedrooms should be located on accessible routes that

lead to all other relevant facilities within the building;

- (i) the size of accessible bedrooms should allow for a wheelchair user to manoeuvre at the side of a bed and transfer independently to it. An example of a wheelchair accessible bedroom is given in Diagram 29;
- (j) en-suite sanitary facilities should comply with 1.4;
- (k) wide angle viewers, where provided in the entrance door to an accessible bedroom, should be located at both 1050 mm and 1500 mm above floor level, to enable viewing by people who are seated or standing;
- (l) a balcony, where provided, should have a door in compliance with Table 2 and have a level threshold;
- (m) there should be no permanent obstructions in a zone 1800 mm back from any balcony door(s) for the full width of the door(s);
- (n) an emergency assistance alarm (plus reset button) should be located in the bedroom and activated by a pull cord, sited so that it can be operated both from the bed and from an adjacent floor area. It should be in accordance with 1.5.6 (e);
- (o) an emergency assistance call signal outside a bedroom should be located so that it can be easily seen and heard by persons able to give assistance and also at a central control point.

# Section 1.5

## Other facilities in buildings other than dwellings

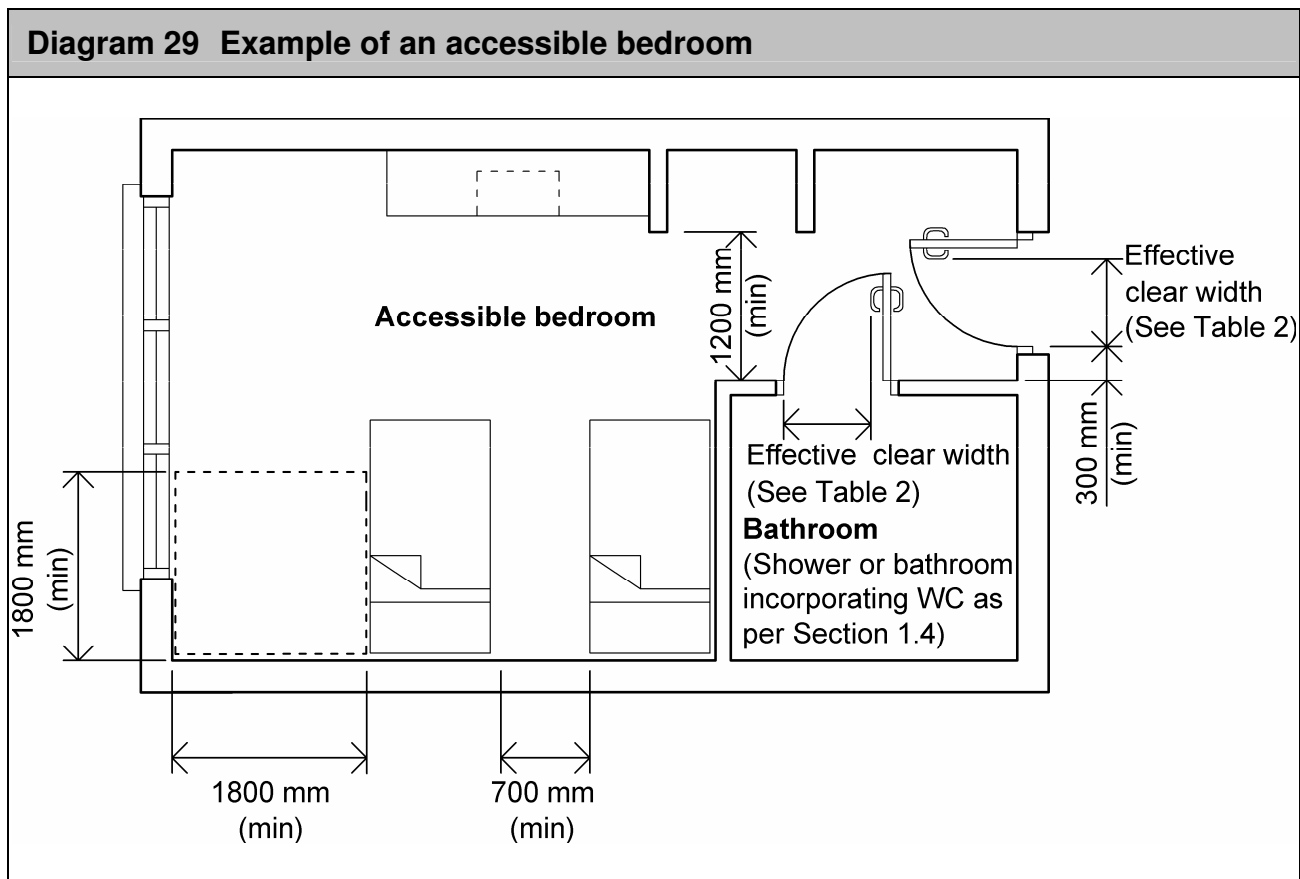

### 1.5.7 Switches, outlets and controls

Where switches, outlets and controls are provided:

- (a) socket outlets should be located between 400 mm and 1200 mm above the floor, with a preference for the lower end of the range. Examples include wall mounted power socket-outlets, telephone points and TV sockets (refer to Diagram 30). Exceptions may be made where floor sockets are provided in open plan areas and the like, or if skirting or dado trunking is required e.g. for safety reasons. These height requirements apply only to convenience socket-outlets used for general purposes and do not apply to dedicated socket-outlets not readily accessible and used for appliances that are intended to be

continuously connected in normal use;

- (b) switches for lighting and permanently wired appliances should be located between 400 mm and 1200 mm above the floor, unless needed at a higher level for particular appliances (refer to Diagram 30). The height requirements apply to all control devices, except where the manufacturers instructions specify otherwise;
- (c) all switches and controls that require precise hand movements should be located between 750 mm and 1200 mm above the floor, e.g. controls for heating systems (refer to Diagram 30);

## Section 1.5

### Other facilities in buildings other than dwellings

---

- (d) simple push button controls that require limited dexterity should be provided and should be located not more than 1200 mm above the floor;
- (e) pull cords for emergency alarm systems should be coloured red, located as close to a wall as possible and have two red 50 mm diameter bangles one set at 100 mm and the other set between 800 mm and 1000 mm above the floor;
- (f) controls that need close vision, e.g. meters or heating controls should be located between 1200 mm and 1400 mm above the floor so that readings may be taken by a person sitting or standing (with thermostats at the top of the range). This does not apply to electricity meters or distribution/fuse boards;
- (g) socket-outlets should be located consistently in relation to doorways and room corners, but in any case no nearer than 350 mm from room corners;
- (h) light switches for use by the general public should have large push pads and align horizontally with door handles within the range 900 mm to 1200 mm for ease of location when entering a room;
- (i) where switches described in (h) cannot be provided, lighting pull cords should be set between 900 mm and 1200 mm above floor level and fitted with a 50 mm diameter bangle visually contrasting with its background and distinguishable visually from any emergency assistance pull cord (refer to 1.6.4) ;
- (j) the operation of switches, socket-outlets and controls should not require the simultaneous use of both hands except where this mode of operation is necessary for safety reasons;
- (k) switched socket-outlets should indicate visually whether they are on or off;
- (l) mains and circuit isolator switches should clearly indicate whether they are on or off;
- (m) controls should visually contrast with their backgrounds to facilitate people with vision impairment locating controls (refer to 1.6.4);
- (n) switches on controls e.g. switched sockets should be adequately separated to allow selection of one at a time and avoid the unintended selection of adjacent switches.

## Section 1.5

### Other facilities in buildings other than dwellings

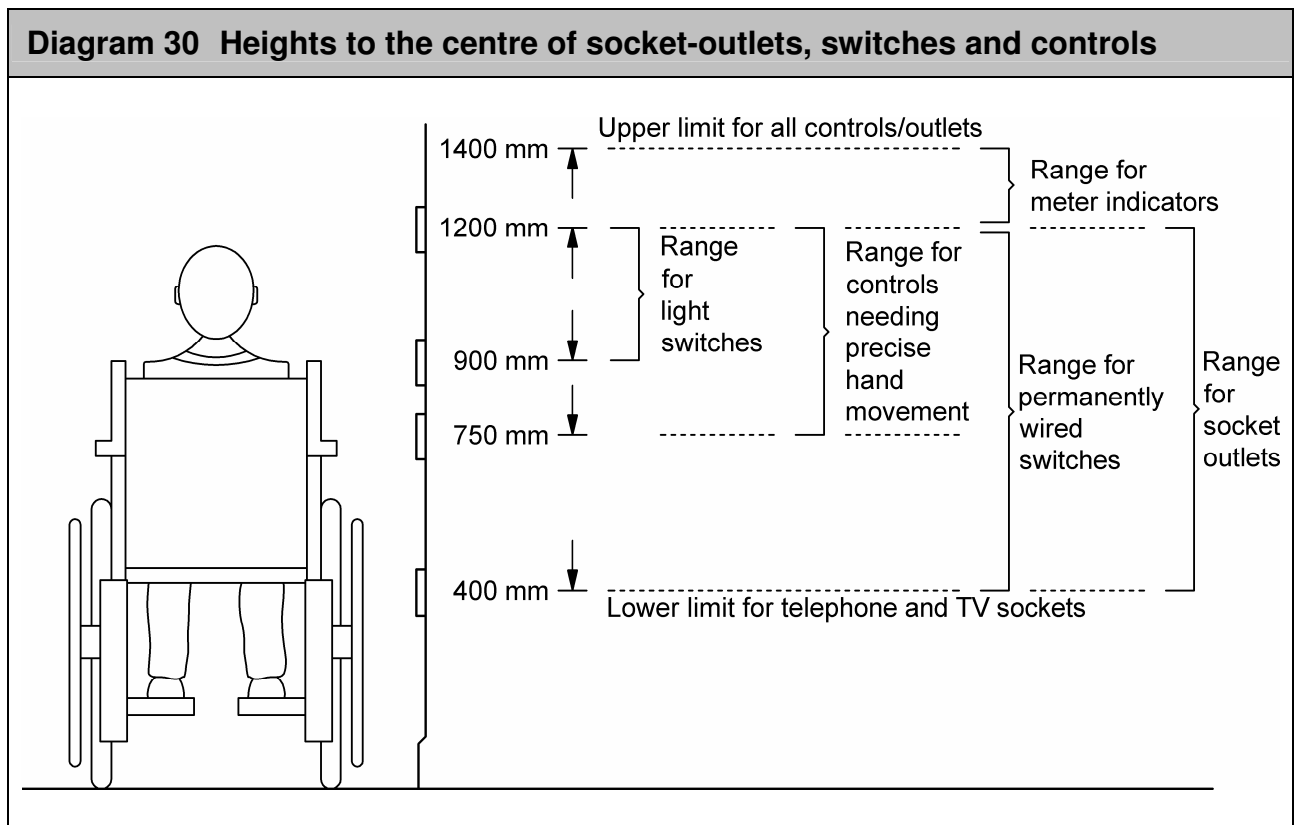

# Section 1.6

## Aids to communication

---

### Section 1.6 Aids to communication

#### 1.6.1 Objective

**The objective is to provide adequate aids to communication to ensure people can independently access and use a building and its facilities.**

#### 1.6.2 Introduction

Signage, visual contrast, lighting and audible aids assist people, especially those people with vision or hearing impairment or people with intellectual disabilities, in accessing a building and fully utilising the relevant facilities in and around a building.

People will benefit most if there is an integrated approach to the design of way finding, public address and hearing enhancements within a building.

In relation to way finding, people use various different strategies and tools to navigate a building. Therefore, to effectively communicate information, directions or instructions to people with a wide range of abilities may require the use of various media. This may result in visual signs, tactile signs and audible aids delivering the same message.

Visual contrast between certain elements also assists in providing spatial information to people with vision impairment and thus facilitates way finding (refer to 1.6.4). Visual contrast sensitivity is the ability to perceive differences between an object and its background e.g. a handle from the door or the nosing from the rest of the step.

The amount of light a surface reflects is known as the Light Reflectance Value (LRV). The range of LRV is 0 (black) to

100 (white). The larger the difference between the LRV of each surface the greater the visual contrast is and the easier it is for someone with a low visual contrast sensitivity to perceive the difference. BS8300:2009 Annex B provides several methods for measuring LRV and provides guidance on acceptable LRV differences between adjoining surfaces. BS 8493:2008 provides LRV measurements for certain colours (as specified in BS 4800:1989).

Lighting is an important feature of a building and directly affects the buildings accessibility and the use of its facilities. Well designed and installed lighting may be used to support way finding, to identify hazards and to improve communication such as lip reading or signing (refer to 1.6.5).

There are several types of audible aids, including:

- (a) **Public address systems:** These should be coupled with audio frequency induction loops and should be supplemented with visual information;
- (b) **Audio frequency induction loop systems:** These can provide assistance to users of personal hearing aids incorporating an induction pick-up facility (T setting);
- (c) **Infra red systems:** These offer line-of-sight wireless communication to specific personal receiver units;
- (d) **Radio systems:** These offer wireless communication without the need for a clear line-of-sight to receiver units.



# Section 1.6

## Aids to communication

---

Throughout this Technical Guidance Document, guidance is given on the provision of signage, visual contrast and hearing enhancement systems as well as the level of lighting required in certain locations. In all these cases the provisions should be based on the following guidance 1.6.3 to 1.6.6.

For additional information and guidance on the provision, design and use of signage, visual contrast, lighting and hearing enhancement systems, refer to Building for Everyone, BS 8300:2009, Sign Design Guide, See it right Signage and The Accessible Office. Also, BS 4800:1989 and BS 5252:1976 provide colour specifications and co-ordination schemes for use in buildings (Refer to Other standards and publications).

### 1.6.3 Signage

Where signage is provided in accordance with the provisions in TGD M:

- (a) signs should be as clear, short and concise as practicable;
- (b) text on signs should not be set entirely in capital letters.  
Rationale: When a combination of capital and lower case letters is used, word shape is easier to recognize, making text easier for many people to read;
- (c) visual signs should be designed with due consideration given to the height of sign, layout of sign, font size, font type, use of symbols and visual contrast with background, etc. For guidance on these elements of sign design refer to BS 8300:2009;
- (d) all key location information, such as sign directories and orientation signs

should be visual and in tactile form when low enough to be touched. Tactile signs should be designed using embossed text, symbols and/or Braille. For guidance on these elements of sign design refer to BS 8300:2009;

- (e) the International Symbol for Access should be provided, where necessary, on signs to features and facilities that are accessible such as entrances, routes, sanitary and other facilities;
- (f) standard symbols in accordance with BS 8501:2002 should be used to indicate the presence of an induction loop or an infrared hearing enhancement system;
- (g) the position of the signage should not create a hazard within a circulation route e.g. signs which require a significant period of time to read should be located where users will not obstruct the passage of other people.

### 1.6.4 Visual contrast

Where visual contrast is provided:

- (a) the difference in the LRV of the surfaces should be 30 points or more when measured in accordance with BS 8300:2009 Annex B or BS 8493:2008. For large areas such as walls and floors a difference in the LRV of 20 points or more is acceptable, provided the illuminance on the surfaces is 200 lux or more. For door opening furniture, a difference in the LRV of 15 points between the product and its background is acceptable;

## Section 1.6

### Aids to communication

---

- (b) the area should be adequately lit in all conditions; should be indicated with clear signage;
- (c) shadows and glare should be avoided e.g. from changing daylight or high gloss surfaces;
- (d) large repeating patterns should be avoided in spaces where visual acuity is critical as they will hamper communication for people who are partially sighted and those who lip-read or use sign language. This would apply to locations such as reception areas with enquiry desks and speakers rostrums in lecture halls.
- (d) a clearly audible public address system should be supplemented by visual information;
- (e) an inductive coupler and additional volume control to adjust amplification should be fitted into the circuitry of all public or visitor payphones, entry phones and emergency phones in lifts;
- (f) induction loops should be designed, installed and commissioned to comply with the International Standard IEC 60118-4.

#### 1.6.5 Lighting

Where artificial lighting is provided, it should give good colour rendering of all surfaces, and should not create glare or pools of bright light and strong shadows, which poorly located up-lighters may create.

#### 1.6.6 Audible aids

Where audible aids are provided:

- (a) the system should enhance sound communicated to the user, whether received directly through a personal hearing aid, through additional equipment supplied as part of the system or other means;
- (b) it should preserve the characteristics of the source, whilst suppressing reverberation and extraneous noise and should not be affected by environmental interference such as from lighting or other electrical installations;
- (c) the presence and type of hearing enhancement system installed

## Section 2 - Access and Use of existing buildings other than dwellings

---

The guidance in Section 2 applies to certain elements and features of existing buildings other than dwellings and their environs.

The guidance in Section 2 also applies to the common areas of existing apartment blocks and their environs.

This Section should be read in conjunction with Section 1 and is intended to provide additional guidance on certain elements and features for existing buildings types as mentioned above.

---

# Section 2 - Access and Use of existing buildings other than dwellings

---

## 2.0 Introduction

Section 1 sets out the minimum level of provision for the following buildings to meet the requirements of M1:

- (a) buildings other than dwellings and their environs; and
- (b) common areas of apartment blocks and their environs

Section 1 applies to new and existing buildings. This section provides additional guidance on the minimum provisions for certain elements and features of existing buildings where it is not practicable to achieve the provisions set out in Section 1. Where works (e.g. material alterations and certain changes of use, etc) to existing buildings are carried out in accordance with Section 1 and 2, this will prima facie indicate compliance with Requirement M1.

Reference should be made to 0.6 and 0.8 for the application of Part M to existing buildings and 0.7 for considerations that should be made when determining 'practicability'.

This section (Section 2) mirrors the structure of Section 1. The provisions in Section 1 apply to existing buildings unless additional guidance on minimum levels is provided in this section.

Works to existing buildings can present many design challenges because of the individual character, appearance and environs of existing buildings. Each existing building and site will present its own unique access opportunities and constraints, which are likely to result in different ways of addressing accessibility. However, the fundamental priorities of accessibility should be the same as those

set out in M1, i.e. accessing and using a building, its facilities and environs.

Whilst the provisions of the Building Regulations do not relate to management or maintenance and compliance with the Regulations is not dependent on these, it is acknowledged that they are important functions and contribute to the ongoing accessibility of the building. Key issues such as arranging furniture appropriately, keeping circulation routes clear, facilities clean, equipment (lifts, communication aids, etc.) functioning, along with staff training and awareness campaigns are generally the responsibility of the management and or maintenance teams. For guidance on managing buildings refer to Building for Everyone, BS 8300: 2009, the NDA publication 'Access Handbook Template' and [www.nda.ie](http://www.nda.ie).

When considering works to an historic building, it is important to establish what is important or significant about the building. Historic buildings can be significant in many different ways, for example, in its physical fabric, in its historical associations or in its archaeological potential. The better the understanding of what is important, the easier it will be to design appropriate accessible solutions. Information about the significance of a building may be obtained from a conservation plan or statement, where these exist, or from the architectural conservation officer from the relevant local authority.

Historic buildings include Protected Structures, which are included by each Planning Authority on a Record of Protected Structures. These buildings have been identified as having particular cultural significance and heritage value.

## Section 2 - Access and Use of existing buildings other than dwellings

---

The adoption without modification of the guidance in this document may not, in all circumstances, be appropriate for historic buildings. Liaison with the local Building Control Authority on alternative approaches based on the principles contained in this document may be more relevant and should be considered.

For further guidance on access to historic buildings refer to 'Advice Series: Access – improving the accessibility of historic buildings and places' by the Department of the Environment, Heritage and Local Government.

### 2.1 Approach to existing buildings other than dwellings

#### 2.1.1 Objective

**The objective is to provide independently accessible means of approach to the accessible entrance(s) of an existing building and means of circulation around an existing building.**

#### 2.1.2 Introduction

The guidance in 1.1.2 should be followed except:

- (a) where it is not practicable to provide both approach routes, as defined in 1.1.2, at least one approach route to an accessible entrance of an existing building should be in accordance with the relevant guidance given in 1.1.2 and 1.1.3, (2.1.2 and 2.1.3, where necessary);
- (b) where it is not practicable to provide circulation routes, as defined in 1.1.1 (c) and (d), that comply with section 1.1.2 and 1.1.3 (2.1.2 and 2.1.3, where necessary) then similar facilities should be provided within

the building or its environs which are accessible to people with disabilities;

- (c) where steps provide the only access to an existing building (i.e. there is no ramp), the stepped approach may need to be modified or an alternative provided. Refer to 2.1.4.5 (d)).
- (d) where level, gently sloped, ramped and stepped access routes exist they should be in accordance with 1.1.3 (2.1.3 where necessary).

### 2.1.3 Access routes

#### 2.1.3.1 General

The guidance in 1.1.3.1 should be followed, where practicable.

#### 2.1.3.2 Level access routes

The guidance in 1.1.3.2 should be followed except:

- (a) where it is not practicable to provide the minimum clear width (between walls, upstands or kerbs) in 1.1.3.2, it should be as wide as possible but not less than 1000 mm;
- (b) it may not be practicable to provide passing places as required in 1.1.3.2 on an existing level access route.

#### 2.1.3.3 Gently sloped access routes

The guidance in 1.1.3.3 should be followed except:

- (a) where it is not practicable to provide the minimum clear width (between walls, upstands or kerbs) in 1.1.3.3, it should be as wide as possible but not less than 1000 mm;

## Section 2 - Access and Use of existing buildings other than dwellings

---

- (b) it may not be practicable to provide passing places in 1.1.3.3 on an existing gently sloped access route;
  - (c) it may not be practicable to provide landings at each rise of 500mm in accordance with 1.1.3.3 on an existing gently sloped access route;
  - (d) where it is not practicable to provide the dimensions of the top and bottom landing in 1.1.3.3, the dimensions should be as large as possible but not less than 1500 mm wide x 1500 mm long, to facilitate wheelchair turning. Where a door opens onto a landing, the length, clear of the door swing or other obstruction, should be not less than 1300 mm long;
  - (e) where it is not practicable to provide the length of an intermediate landing in 1.1.3.3, it should be as long as possible but not less than 1000 mm long. Where a door opens onto a landing, the length of the landing should be at least 1300 mm clear of the door swing;
  - (f) where it is not practicable to provide the dimensions in 1.1.3.3 for intermediate landings to act as passing places, the dimensions should be at least those in (c) above.
- 2.1.3.4 Ramped access routes**
- The guidance in 1.1.3.4 should be followed except:
- (a) where it is not practicable to provide the minimum clear width (between walls, upstands or kerbs) in 1.1.3.4, it should be as wide as possible, but the minimum unobstructed width between handrails should be not less than 1000 mm;
  - (b) where it is not practicable to provide ramp gradients in accordance with 1.1.3.4, a ramp with a gradient of 1:20 should not have goings longer than 10 m, a maximum gradient of 1:12 may be provided if individual ramp goings are not longer than 4500 mm, (interpolation between these is permitted);
  - (c) where it is not practicable to provide the stated dimensions of the top and bottom landing in 1.1.3.4, the dimensions should be as large as possible but not less than 1500 mm wide x 1500 mm long, to facilitate a wheelchair turning. Where a door opens onto a landing, the length should be at least 1300 mm long and clear of any door swings or other obstructions;
  - (d) where it is not practicable to provide the length of an intermediate landing in 1.1.3.4, it should be as long as possible but not less than 1000 mm long. Where a door opens onto a landing, the length of the landing should be at least 1300 mm clear of the door swing;
  - (e) where it is not practicable to provide the dimensions in 1.1.3.4 for intermediate landings to act as passing places, the dimensions should be at least those in (d) above;
  - (f) if edge protection exists on the open side of any ramp or landing in the form of an upstand or kerb it should be at least 75 mm high;
  - (g) it may not be practicable to provide a stepped access route in addition to a ramp where the rise of the ramp is

## Section 2 - Access and Use of existing buildings other than dwellings

---

greater than 300 mm (refer to 1.1.3.4 (h)).

### 2.1.3.5 Stepped access routes

The guidance in 1.1.3.5 should be followed except:

- (a) where it is not practicable to provide the minimum clear width (between walls, upstands or kerbs) in 1.1.3.5, it should be as wide as possible, but the minimum unobstructed width between handrails should be not less than 1000 mm;
- (b) where it is not practicable to provide the length of landings in 1.1.3.5, the length should be as long as possible but not less than 1000 mm long and clear of any door or gate swings;
- (c) where it is not practicable to provide steps with the stated goings in 1.1.3.5, they should be as large as possible but, with a going not less than 280 mm;
- (d) where it is not practicable to provide a stepped approach to an existing building, to meet the minimum provisions in 1.1.3.5 (and 2.1.3.5, where necessary), one of the following alternatives should be provided where practicable:
  - (i) landscape or re-align the approach to provide a level, gently sloped or ramped access route and new steps where necessary; or
  - (ii) retain the existing steps and install an external platform lift in accordance with BS 6440<sup>3</sup>; or

- (iii) revise the internal planning of the building to change the main approach to one that can be made accessible in accordance with 1.1.3 (and 2.1.3 where necessary).

### 2.1.3.6 Handrails

The guidance in 1.1.3.6 should be followed, except:

- (a) it may not be practicable to provide the heights to the top of handrails in 1.1.3.6. The vertical height to the top of an existing handrail should be between 840 to 1000 mm above the pitch line of the ramp or the flight of steps and between 840 mm and 1100 mm above the surface of the landing;
- (b) it may not be practicable to provide the clearance between the handrail and any adjacent wall surface in 1.1.3.6 (g) however, the clearance for an existing handrail should not be less than 45 mm;
- (c) it may not be practicable to provide the clearance between a cranked support and the underside of the handrail in 1.1.3.6 (h) however, the clearance for an existing handrail should not be less than 30 mm;

---

<sup>3</sup> Platform lifts should comply with the Machinery Directive 2006/42/EC. BS 6400:1999 is partially superseded by EN 81-40:2008. The remainder will eventually be superseded by EN 81-41.

# Section 2 - Access and Use of existing buildings other than dwellings

---

## 2.1.4 Pedestrian crossings

The guidance in 1.1.4 should be followed.

## 2.1.5 On-site car parking

The guidance in 1.1.5 should be followed, where practicable. Where on-site car parking is provided and it is not practicable to provide the number of designated car parking spaces in 1.1.5, as many as possible should be provided but at least one. Alternatively a setting down area should be provided.

## 2.1.6 On-site setting down areas

The guidance in 1.1.6 should be followed.

## 2.2 Access to existing buildings other than dwellings

### 2.2.1 Objective

**The objective is to provide entrances to existing buildings that are independently accessible and to avoid segregation based on a person's level of ability.**

### 2.2.2 Introduction

The guidance in 1.2.2 should be followed. Where it is not practicable for each of the applicable entrance(s) set out in 1.2.2 to be accessible, alternative accessible entrance(s) should be provided or the internal planning of the building revised to change the applicable entrance(s) to one(s) that can be made accessible in accordance with 1.2 and 2.2 where necessary. At least one entrance should be made accessible.

### 2.2.3 Accessible entrances

The guidance in 1.2.3 should be followed. Where it is not practicable to provide the dimensions of the landing in front of every accessible entrance in 1.2.3, the dimensions should be as large as

possible but not less than 1500 mm wide x 1500 mm deep.

## 2.2.4 Accessible entrance doors

The guidance in 1.2.4 should be followed except:

- (a) where it is not practicable to provide an entrance door with an effective clear width in accordance with 1.2.4, the effective clear width should be as wide as possible but not less than 750 mm however, where the existing frontage and entrance door(s) are being replaced, an effective clear door width in accordance with 1.2.4 should be provided.
- (b) where it is not practicable to provide the minimum vertical zone of visibility in accordance with 1.2.4, the zone should be as large as possible but not less than between 900 mm and 1500 mm from the floor.

### 2.2.4.1 Accessible glass doors

The guidance in 1.2.4.1 should be followed, where practicable.

### 2.2.4.2 Accessible manual doors

The guidance in 1.2.4.2 should be followed, where practicable.

### 2.2.4.3 Accessible power-operated doors

The guidance in 1.2.4.3 should be followed.

### 2.2.4.4 Low energy swing doors

The guidance in 1.2.4.4 should be followed.



## Section 2 - Access and Use of existing buildings other than dwellings

---

### 2.2.5 Entrance lobbies

The guidance in 1.2.5 should be followed, where practicable. Where in an existing building, an entrance lobby is provided with automatic doors, the width of the lobby should be at least equal to the effective clear width of the door + 300 mm and the length sufficient to accommodate a wheelchair.

### 2.3 Circulation within existing buildings other than dwellings

#### 2.3.1 Objective

**The objective is for people to travel horizontally and vertically within an existing building conveniently and without discomfort in order to make use of relevant facilities.**

#### 2.3.2 Introduction

The guidance in 1.3.1 and 1.3.2 should be followed.

#### 2.3.3 Horizontal features

##### 2.3.3.1 Reception area in entrance halls

The guidance in 1.3.3.1 should be followed, where practicable.

##### 2.3.3.2 Internal doors

The guidance in 1.3.3.2 should be followed except where it is not practicable to provide a door with an effective clear width in accordance with 1.3.3.2, the effective clear width should be as wide as possible but not less than 750 mm.

##### 2.3.3.3 Corridors and passageways

The guidance in 1.3.3.3 should be followed except:

- (a) where it is not practicable to maintain the minimum unobstructed clear corridor width in 1.3.3.3 it should be as wide as possible but

not less than 1000 mm. Elements such as columns, radiators and fire hoses should not project into this corridor width;

- (b) where it is not practicable to provide a passing place at all locations in 1.3.3.3, they should be provided where practicable;
- (c) where it is not practicable to provide the length of rest area in 1.3.3.3 for a gently sloping gradient, the length should be as long as possible but not less than 1000 mm;
- (d) an alternative to providing a slope or ramp between a change in height is to provide a platform lift in accordance with BS 6440:1999.

##### 2.3.3.4 Internal lobbies

The guidance in 1.3.3.4 should be followed where practicable. Where in an existing building, a lobby is provided with automatic doors, the width of the lobby should be at least equal to the effective clear width of the door + 300 mm and the length sufficient to accommodate a wheelchair.

#### 2.3.4 Vertical features

##### 2.3.4.1 Provision

The guidance in 1.3.4.1 should be followed except where it is not practicable to provide a passenger lift in an existing building, an enclosed vertical lifting platform should be provided in accordance with 2.3.4.1.1. Alternatively, the same range of services/ facilities that are available on the other levels should be made available on the entry or accessible level(s).

## Section 2 - Access and Use of existing buildings other than dwellings

---

### 2.3.4.1.1 Lifts

The guidance in 1.3.4.1 should be followed except where the provisions of 2.3.4.1 apply.

Where a vertical lifting platform is provided in an existing building:

- (a) it should comply with the Machinery Directive 2006/42/EC;
- (b) it should conform to BS 6440:1999<sup>3</sup>;
- (c) signs should be provided to facilitate finding the lifting device (refer to 1.6.3 and 2.6.3 where applicable);
- (d) the minimum clear dimensions of a platform lift should be 1100 mm wide x 1400 mm deep;
- (e) doors or access openings to lifting platforms should have a minimum effective clear width of 800 mm;
- (f) controls for lifting platforms should be located between 800 mm and 1200 mm above finished floor level and a minimum of 400 mm from any return wall;
- (g) controls for landings should be located between 900 mm and 1100 mm above finished floor level and minimum of 500 mm from any return wall.

### 2.3.4.1.2 Stairs

Refer to 2.3.4.3.

### 2.3.4.2 Passenger lift details

The guidance in 1.3.4.2 should be followed except:

- (a) where it is not practicable to provide the manoeuvring space in front of the lift, the manoeuvring space should be as large as possible but not less than 1500 mm wide and 1500 mm deep;
- (b) where it is not practicable to provide a larger lift in the public areas of public facilities as per 1.3.4.2 (j), the minimum internal dimensions of a lift car of 1100 mm wide x 1400 mm deep should be provided.

### 2.3.4.3 Internal stairs suitable for ambulant disabled people

Where a lifting device is provided in accordance with 1.3.4 and where necessary 2.3.4 to all floors in an existing building, an internal stairs suitable for ambulant disabled people is not necessary.

Where internal stairs suitable for ambulant disabled people are provided in existing buildings the guidance in 1.3.4.3 should be followed except:

- (a) where it is not practicable to provide the minimum clear width in 1.3.4.3, it should be as wide as possible, but the minimum unobstructed width between handrails should be not less than 1000 mm;
- (b) where it is not practicable to provide the length of landings in 1.3.4.3, the length should be as long as possible but not less than 1000 mm long and clear of any door or gate swings;

---

<sup>3</sup> Platform lifts should comply with the Machinery Directive 2006/42/EC. BS 6400:1999 is partially superseded by EN 81-40:2008. The remainder will eventually be superseded by EN 81-41.

## Section 2 - Access and Use of existing buildings other than dwellings

---

- (c) where it is not practicable to provide steps with the going in 1.3.4.3, they should be as large as possible but with a going not less than 250 mm.

### 2.3.4.4 Internal ramps

The guidance in 1.3.4.4 should be followed except:

- (a) where it is not practicable to provide the minimum clear width in 1.1.3.4, it should be as wide as possible, but the minimum unobstructed width between handrails should be not less than 1000 mm;
- (b) where it is not practicable to provide ramp gradients in accordance with 1.1.3.4, a ramp with a gradient of 1:20 should not have going longer than 10 m, a maximum gradient of 1:12 may be provided if individual ramp goings are not longer than 4500 mm, (interpolation between these is permitted);
- (c) where it is not practicable to provide the stated dimensions of the top and bottom landing in 1.1.3.4, the dimensions should be as large as possible but not less than 1500 mm wide x 1500 mm long, to facilitate a wheelchair turning. Where a door opens onto a landing, the length should be at least 1300 mm long and clear of any door swings or other obstructions;
- (d) where it is not practicable to provide the length of an intermediate landing in 1.1.3.4, it should be as long as possible but not less than 1000 mm long and clear of any door swings or other obstructions;

- (e) where it is not practicable to provide the dimensions in 1.1.3.4 for intermediate landings to act as passing places, the dimensions should be at least those in (d) above;

- (f) if edge protection exists on the open side of any ramp or landing in the form of an upstand or kerb it should be at least 75 mm high.

- (g) where it is not practicable to provide a stepped access route in addition to a ramp where the rise of the ramp is greater than 300 mm (refer to 1.1.3.4 (h)) then a ramp alone will be sufficient.

### 2.3.4.5 Handrails

The guidance in 1.3.4.5 should be followed where practicable.

## 2.4 Sanitary facilities in existing buildings other than dwellings

### 2.4.1 Objective

**The objective is to provide independently accessible sanitary facilities that meet the needs of people with a wide range of abilities.**

### 2.4.2 Introduction

Specific guidance on the provision of sanitary facilities is given in 1.4.3 and where necessary 2.4.3. Detailed guidance on the design of the sanitary facilities is given in 1.4.4 to 1.4.9.

### 2.4.3 General provisions

Guidance on the provision of accessible sanitary facilities in 1.4.3 should be followed except:

- (a) where there is more than one WC facility provided at different locations

## Section 2 - Access and Use of existing buildings other than dwellings

---

within an existing building, at least one accessible unisex WC should be provided on each accessible floor which has a WC facility;

- (b) where it is not practicable to provide doors to accessible sanitary facilities with a clear effective width in accordance with 1.3.3.2, the doors should be as wide as possible but not less than 750 mm;
- (c) where it is not practicable to provide a wheelchair accessible unisex WC with a minimum turning space of 1800 mm x 1800 mm, a minimum turning space of 1500 mm x 1500 mm may be provided (refer to Diagram 15b);
- (d) where it is not practicable to provide a WC cubicle(s) for ambulant disabled people and/or enlarged cubicles in accordance with 1.4.6.2 and 1.4.6.3 respectively, ambulant disabled WC cubicle(s) in accordance with Diagram 31 may be provided.

# Section 2 - Access and Use of existing buildings other than dwellings

**Diagram 31 WC cubicle for ambulant disabled people in an existing building**

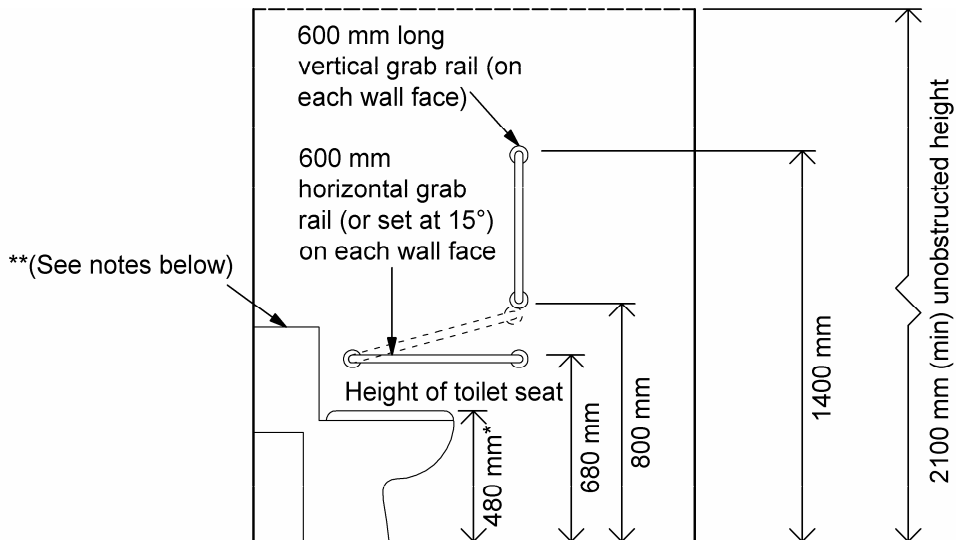

**a) Elevation**

Length of cubicle depends on projection of WC pan from rear wall and direction of door swing

\*\* (See notes below)

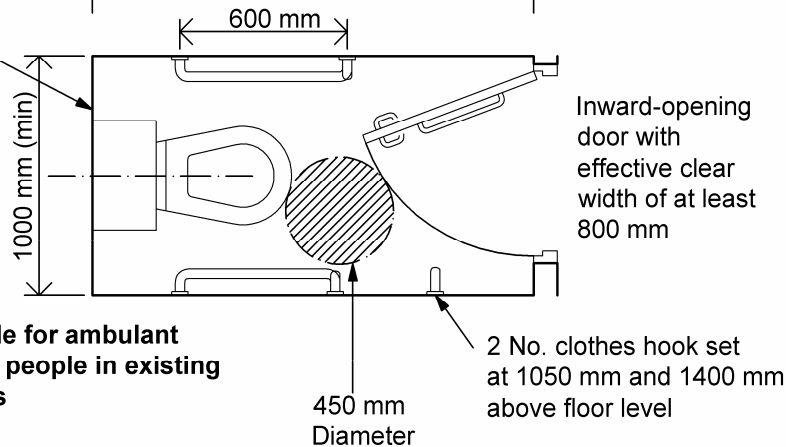

**a) Cubicle for ambulant disabled people in existing buildings**

**NOTE:**

\*Height subject to manufacturing tolerance of WC pan

\*\*Where high or low level cisterns are used, a rail with a padded back rest and a separate colostomy changing shelf 125 mm to 150 mm deep x 400 mm (min) wide with its surface 950 mm above floor level should be provided. Where a flat topped close-coupled cistern is used, the cistern should be adequate to also act as a back rest. If the top of the cistern is flat it should be adequate to facilitate a colostomy changing surface for standing users without the extra requirement for a separate shelf.

The overall dimensions should exclude such items as heat emitters, skirting boards, tiles and boxing in of pipework. Adjustments in room sizes will be needed to accommodate these items.

## Section 2 - Access and Use of existing buildings other than dwellings

---

### 2.5 Other facilities in existing buildings other than dwellings

#### 2.5.1 Objective

**The objective is to ensure that facilities within an existing building are accessible to and useable and that they are designed and constructed to facilitate active participation where appropriate.**

#### 2.5.2 Introduction

The guidance in 1.5.2 should be followed, where practicable.

#### 2.5.3 Audience and spectator facilities with fixed seating

The guidance in 1.5.3 should be followed, where practicable.

#### 2.5.4 Audience and spectator facilities without fixed seating

The guidance in 1.5.4 should be followed, where practicable.

#### 2.5.5 Refreshment facilities

The guidance in 1.5.5 should be followed except:

- (a) where it is not practicable to provide access to users to all parts of the facility as in 1.5.5, a refreshment facility should be available in the accessible area;
- (b) where it is not practicable to provide the minimum clear manoeuvring space in 1.5.5, a minimum clear manoeuvring space of 1500 mm x 1500 mm should be provided in front of a counter or bar outside of any circulation route;
- (c) where it is not practicable to provide a working surface of a bar to facilitate permanent access by

wheelchair users as per 1.5.5 (b), the serving counter should be as wide as possible but at least 900 mm long and at a level of not more than 850 mm above the floor;

#### 2.5.6 Accessible sleeping accommodation

The guidance in 1.5.6 should be followed except where it is not practicable to provide doors to accessible sleeping accommodation with a clear effective width in accordance with 1.3.3.2; the doors should be as wide as possible but not less than 750 mm.

#### 2.5.7 Switches, outlets and controls

The guidance in 1.5.7 should be followed, where practicable.

### 2.6 Aids to communication

#### 2.6.1 Objective

**The objective is to provide adequate aids to communication to ensure people can independently access and use an existing building and its facilities.**

#### 2.6.2 Introduction

The guidance in 1.6 should be followed where practicable.

#### 2.6.3 Signage

The guidance in 1.6.3 should be followed, where practicable.

#### 2.6.4 Visual contrast

The guidance in 1.6.3 should be followed, where practicable.

#### 2.6.5 Audible aids

The guidance in 1.6.3 should be followed, where practicable.

## Section 3

# Access and Use of dwellings

---

The guidance in Section 3 applies to dwellings and their environs. This includes individual dwelling houses and individual apartments. It does not apply to the common areas of apartment blocks. Guidance on these areas is provided in Section 1.

The guidance in Section 3 also applies to the common areas of duplex buildings.

---

# Section 3.1

## Approach to dwellings

---

### Section 3.1 Approach to dwellings

#### 3.1.1 Objective

**The objective is to provide an adequate means of approach to the main entrance of a dwelling to facilitate visitors from a point of access.**

#### 3.1.2 Access route to a dwelling

The point of access is:

- (a) the entrance at the boundary of a dwelling plot<sup>6</sup>, or
- (b) the point at which a person visiting a dwelling would normally alight from a vehicle within the dwelling plot<sup>6</sup>, prior to approaching the dwelling where:
  - (i) the distance between the point of access along the boundary and the main entrance, is greater than 30 m, or
  - (ii) the site gradient is such that the relative finished levels at the dwelling entrance and the point of access along the boundary do not allow for the provision of the appropriate level gently sloped or ramped approach.

At least one approach route from a point of access to the main entrance should be an access route in accordance with 3.1.2.1 to 3.1.2.5. Guidance on the approach to apartment blocks is given in Section 1.1.

#### 3.1.2.1 General

The following guidance applies to all access routes, whether level, gently sloped, ramped or stepped. Additional specific guidance on the above four types of access route is given in 3.1.2.2 to 3.1.2.5.

Where an access route is provided

- (a) the clear opening width of at least one point of access should be a minimum of 900 mm. The access route, leading from this, should maintain a clear width of at least 900 mm and have a firm and even surface, which is suitable for people using wheelchairs or other mobility aids and reduces the risk of slipping;
- (b) the approach may, in whole or in part, form part of an on site driveway. Where this occurs, the driveway should be at least 3600 mm wide so as to allow adequate access width beside parked cars;
- (c) a raised kerb, at least 100 mm high, should be provided on any open side of an approach where the adjacent ground is not graded to the approach. Refer to TGD K for guidance on the provision of guarding;
- (d) the minimum headroom provided on an approach route should be 2100 mm. The underside of stairs, ramps or similar features that restrict headroom below this level should be enclosed.

---

<sup>6</sup> The dwelling plot can be taken to mean the private lands associated with the dwelling.



# Section 3.1

## Approach to dwellings

---

### 3.1.2.2 Level access route

The dwelling should be designed, within the overall constraints of space, so that the difference in level between the entrance to the dwelling and the dwelling plots point of access is minimised. A level approach route accommodates the widest range of abilities. For the purpose of this guidance document a gradient of 1:50 or less steep is considered to be level. For background information on approaches refer to Section 1.1.

### 3.1.2.3 Gently sloped access route

Where site gradients do not allow a level access route, the flattest gradient achievable should be used. Access routes of 1:20 or less steep are preferred.

For the purpose of this guidance document a gradient steeper than 1:50 (but less steep than 1:20) is considered to be gently sloped.

### 3.1.2.4 Ramped access route

Where a ramped access route is necessary due to site constraints it should be designed to have the shallowest gradient practicable. For the purpose of this guidance document a gradient of 1:20 or steeper (but not exceeding 1:12) is considered to be a ramp.

**In addition to the general guidance given in 3.1.2.1** where a ramped access route is provided:

- (a) level landings should be provided between ramp flights or wherever a change in direction occurs. A level landing is considered to include gradients of 1:50 or less steep;
- (b) the length of all landings should be not less than 1200 mm exclusive of

the swing of any door or gate, which opens onto it;

- (c) where the gradient is between 1:20 and not exceeding 1:15 the length between level landings should be a maximum 10 m;
- (d) where the gradient is between 1:15 and 1:12 the length between level landings should be maximum 5 m.

### 3.1.2.5 Stepped access route

Where it is not practicable to provide the required level, gently sloped or ramped approach to the dwelling entrance from the point of access, a stepped approach may be used. This may arise:

- (i) where the gradient between the point of access and the main entrance of the dwelling is steeper than 1:15 and it is not practicable to locate the dwelling entrance in a location to achieve a level, gently sloped or ramped access;
- (ii) where there is insufficient space between the point of access and the main entrance of the dwelling to provide for ramps and landings because of the need to conform to the existing building line and levels;
- (iii) where planning requirements exist e.g. in relation to flood plains; or
- (iv) where the dwelling entrance is at other than the ground floor level of the building, e.g. duplex buildings. Note: The ground floor level of a duplex building should not use a stepped approach.

## Section 3.1

### Approach to dwellings

---

Where a stepped approach is used, it should be suitable for use by ambulant disabled people and **in addition to the general guidance given in 3.1.2.1** should comply with the following:

- (a) it should have a minimum unobstructed width of not less than 900 mm between handrails;
- (b) the rise of a flight between landings should be not more than 1800 mm;
- (c) it should have top and bottom landings and, if necessary, intermediate level landings, each of which should be at least 900 mm long, clear of any door swings or other obstructions;
- (d) steps should have suitable tread/nosing profiles in accordance with Diagram 32 and the rise of each step should be uniform and be between 100 mm and 150 mm;
- (e) the going of each step should be uniform and not less than 280 mm;
- (f) the use of tapered steps should be avoided as the varying tread width of a tapered step can cause people to misjudge distances and can lead to falls. If it is necessary to use them, they should be situated at the bottom of the stairs and the going should not be less than 280 mm, measured at a point 270 mm from the inside (narrowest edge) of the flight, and
- (g) there should be a suitable continuous handrail, as detailed in Section 1.1, on both sides of the flights and intermediate landings, if the flight comprises three or more

risers. Where a shallow stepped approach with goings at least 750 mm long is used, handrails need not be provided.

Refer to TGD K for guidance on the provision of guarding.

# Section 3.1

## Approach to dwellings

**Diagram 32 Examples of external step profiles**

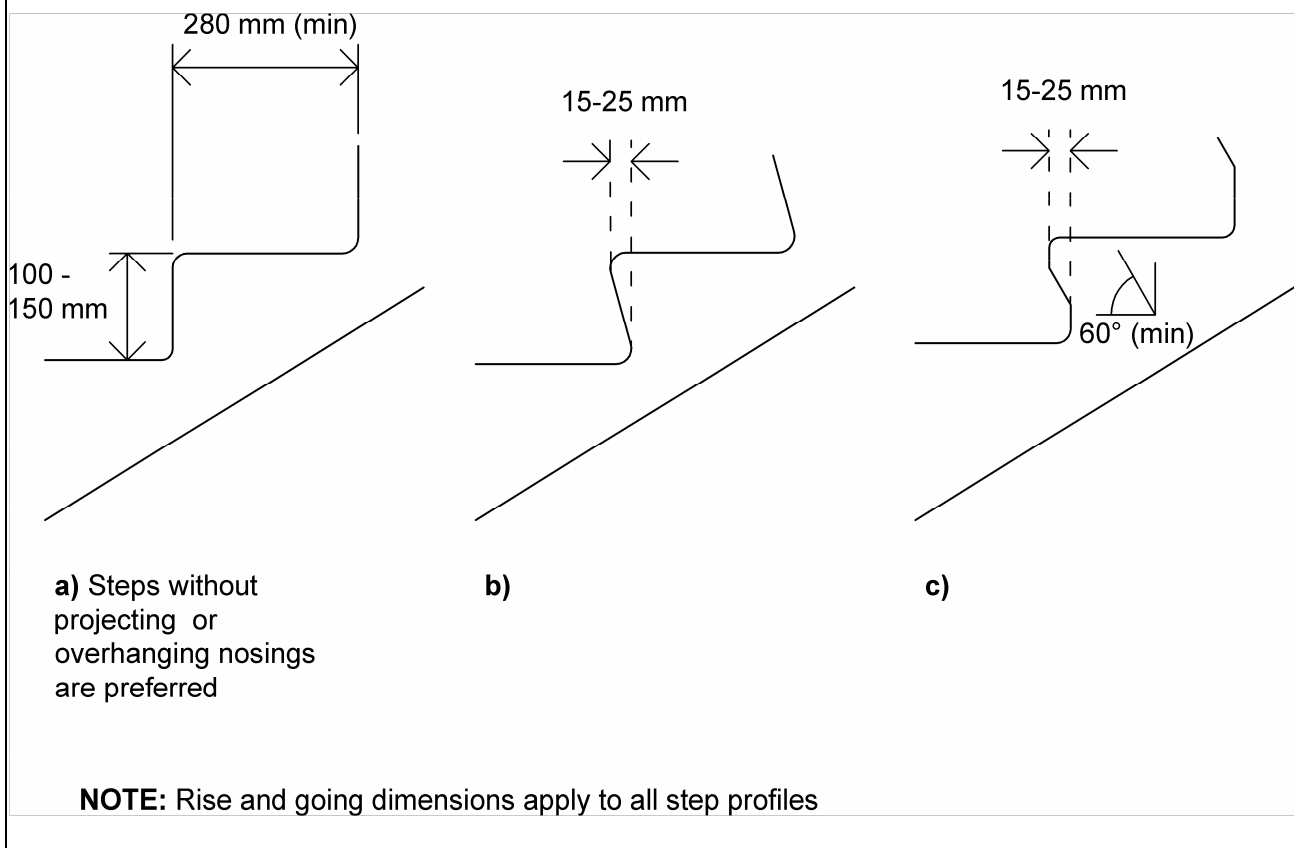

## Section 3.2

### Access to dwellings

---

#### Section 3.2 Access to dwellings

##### 3.2.1 Objective

**The objective is to provide a main entrance to a dwelling that is accessible to visitors.**

##### 3.2.2 Accessible entrance

The main entrance is the entrance, which a visitor not familiar with the dwelling would normally expect to approach.

Where it is not practicable for the main entrance to a dwelling to be accessible, an alternative entrance should be accessible. The alternative accessible entrance should be approached via an access route, conforming to Section 3.1, and be within the public realm of the dwelling plot e.g. the external area accessible to a visitor, unfamiliar with the dwelling. The accessible entrance should be suitable for use by wheelchair users.

External steps should comply with the guidance given in Section 3.1.

Internal steps should comply with the guidance in Section 3.3.

Where an accessible entrance is provided:

- (a) there should be a clear level area at least 1200 mm wide and at least 1200 mm deep in front of every accessible entrance. Where a level entry is provided, regard should be had to the requirements of the Building Regulations generally, particularly in relation to resistance to weather and ground moisture. Guidance on the issues involved in the provision of level entry can be

found in the publication 'Accessible thresholds in new housing';

- (b) the entrance should be provided with a level entry i.e. with maximum threshold height of 15 mm with exposed edges chamfered or pencil rounded;
- (c) the minimum effective clear opening width of the entrance door should be 800 mm;
- (d) in exceptional circumstances, where it is not practicable to provide a level entry to a dwelling, one or more steps may be used. This may arise where there is insufficient space between the point of access and the entrance of the dwelling to provide a suitable level landing because of the need to conform to the existing building line or where the entrance storey does not contain at least one habitable room.

# Section 3.3

## Circulation within dwellings

---

### Section 3.3 Circulation within dwellings

#### 3.3.1 Objective

**The objective is to facilitate circulation of visitors within the entrance storey, or where there is no habitable room at this level, in the storey containing the main living room.**

#### 3.3.2 Circulation within a dwelling

##### 3.3.2.1 Horizontal circulation within a dwelling

Corridors, passageways and doors to habitable rooms in the entrance storey or, where there is no habitable room at this level, in the storey containing the main living room, should be sufficiently wide and free of stepped changes of level so as to allow convenient circulation.

<b>Minimum effective clear width</b>	<b>Minimum unobstructed corridor width</b>
775 mm	1050 mm (900 mm if approached head on)
800 mm	900 mm

Corridors and passageways should have a minimum unobstructed width of not less than 900 mm to facilitate circulation of people using wheelchairs. Localised permanent obstructions, such as radiators, may be allowed, provided that the unobstructed width in those areas is at least 800 mm and the obstruction does not occur opposite a door.

Doors to accessible habitable rooms should be designed and constructed so that the minimum effective clear width, in relation to the adjacent unobstructed corridor width, complies with Table 4.

The length of unobstructed corridor complying with the minimum width requirement specified should be at least 1200 mm approaching any door (refer to Diagram 33).

Saddle boards, where provided, should be bevelled, with a maximum upstand of 10 mm.

Doors to rooms (other than cloak rooms, hot presses, etc), which can only be accessed by the use of steps or stairs, may have a minimum effective clear width of 750 mm.

Diagram 33 illustrates the guidance on internal doors, corridors and passageways for convenient wheelchair use in the entrance storey or, where there is no habitable room at this level, in the storey containing the main living room.

Door handles should be located at a height of between 800 mm and 1200 mm (900 mm preferred) above floor level.

Where a stepped change of level is provided within the storey, e.g. because of the slope of the site, it should be located so that at least one habitable room and a room containing a WC can be accessed from the accessible entrance without the need to negotiate the step(s).

# Section 3.3

## Circulation within dwellings

**Diagram 33 Corridors, passageways and internal doors to dwellings (showing measurement of effective clear width)**

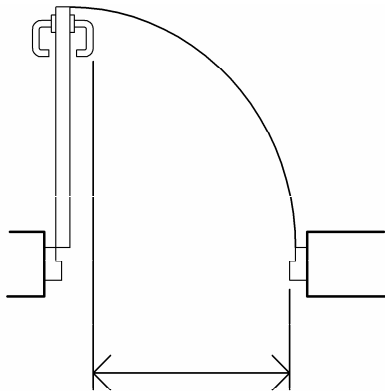

**(i)** Effective clear width (door stop to projecting ironmongery)

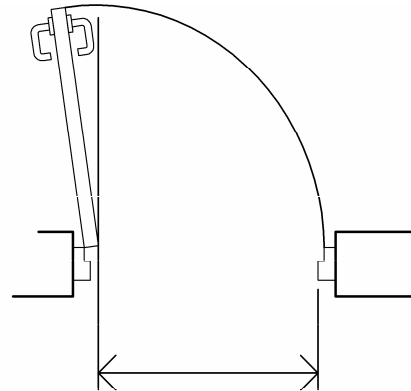

**(ii)** Effective clear width (door stop to door leaf)

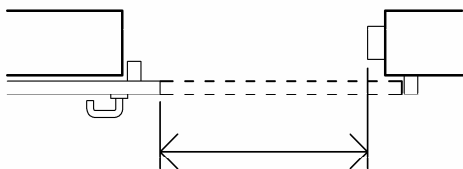

**(iii)** Effective clear width for sliding door (door stop to door leaf)

**a) Determination of effective clear width through a doorway**

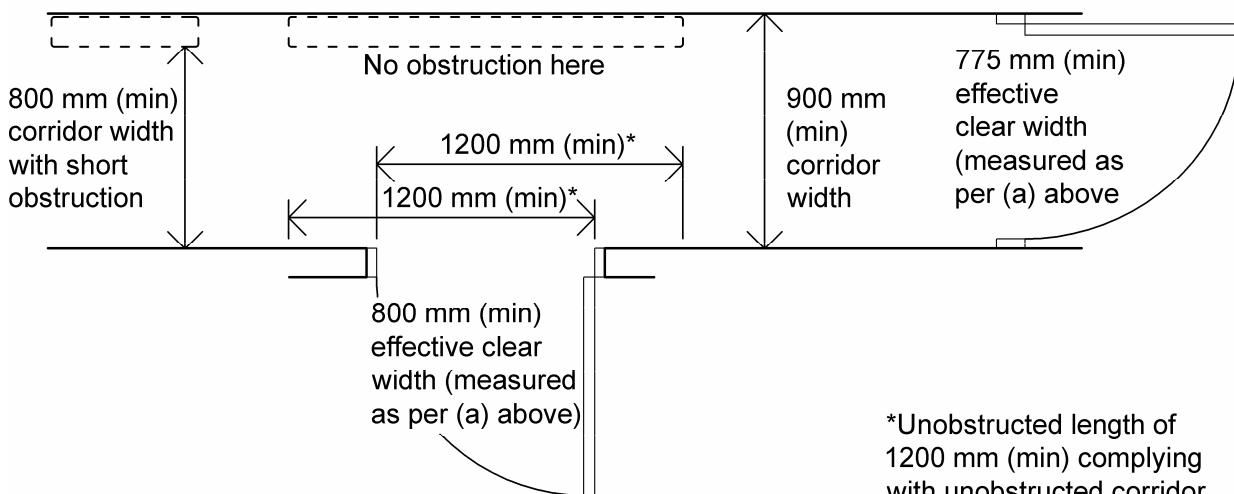

**b) Visitability requirements of internal doors**

## Section 3.3

### Circulation within dwellings

---

#### 3.3.2.2 Vertical circulation within a dwelling

Where there is no habitable room at the entry level, the stairway providing access to the storey containing the main living room should comply with the following:

- (a) It should have a minimum unobstructed width of not less than 900 mm between handrails;
- (b) The rise of a flight between landings should be not more than 1800 mm;
- (c) It should have top and bottom landings and if necessary, intermediate landings, each of which should be at least 900 mm long;
- (d) The rise of each step should be uniform and not more than 175 mm;
- (e) The going of each step should be uniform and not less than 280 mm;
- (f) The use of tapered steps should be avoided as the varying tread width of a tapered step can cause people to misjudge distances and can lead to falls. If it is necessary to use them, they should be situated at the bottom of the stairs and the going should not be less than 280 mm, measured at a point 270 mm from the inside (narrowest edge) of the flight, and
- (g) There should be a suitable continuous handrail, in accordance with 1.1.3.6 on each side of the flights and intermediate landings, if the flight comprises of three or more risers.

# Section 3.4

## Sanitary facilities for dwellings

---

### Section 3.4

#### Sanitary facilities for dwellings

##### 3.4.1 Objective

**The objective is to provide a WC that is accessible to visitors.**

##### 3.4.2 Accessible WC

A WC should be provided at entry level or, where there is no habitable room at this level, in the storey containing the main living room. At entry level, the WC should be so located that it can be accessed from the accessible entrance and from at least one habitable room without the need to negotiate steps. The approach route to the WC should be in accordance with Section 3.3.

The WC should be located in a bathroom or separate WC compartment, the layout of which should be designed to facilitate access to, and use of, the WC by persons with a range of abilities. A clear space of 750 mm by 1200 mm, accessible by people using wheelchairs, should be available adjacent to the WC so as to facilitate sideways transfer from the wheelchair to the WC.

The size and layout of the bathroom or WC compartment, and the positioning of the door, should be such that a wheelchair can be fully contained within the compartment and the door closed with the wheelchair inside. Diagram 34 shows two examples of alternative layouts for WC compartments, which illustrate the level of provision which is generally considered acceptable.

The general headroom available in the WC compartment should be 2100 mm minimum. Local areas with head height less than 2100 mm are acceptable subject to the limits set out in Diagram 34.



# Section 3.4

## Sanitary facilities for dwellings

**Diagram 34 Examples of WC cubicles for visitable housing**

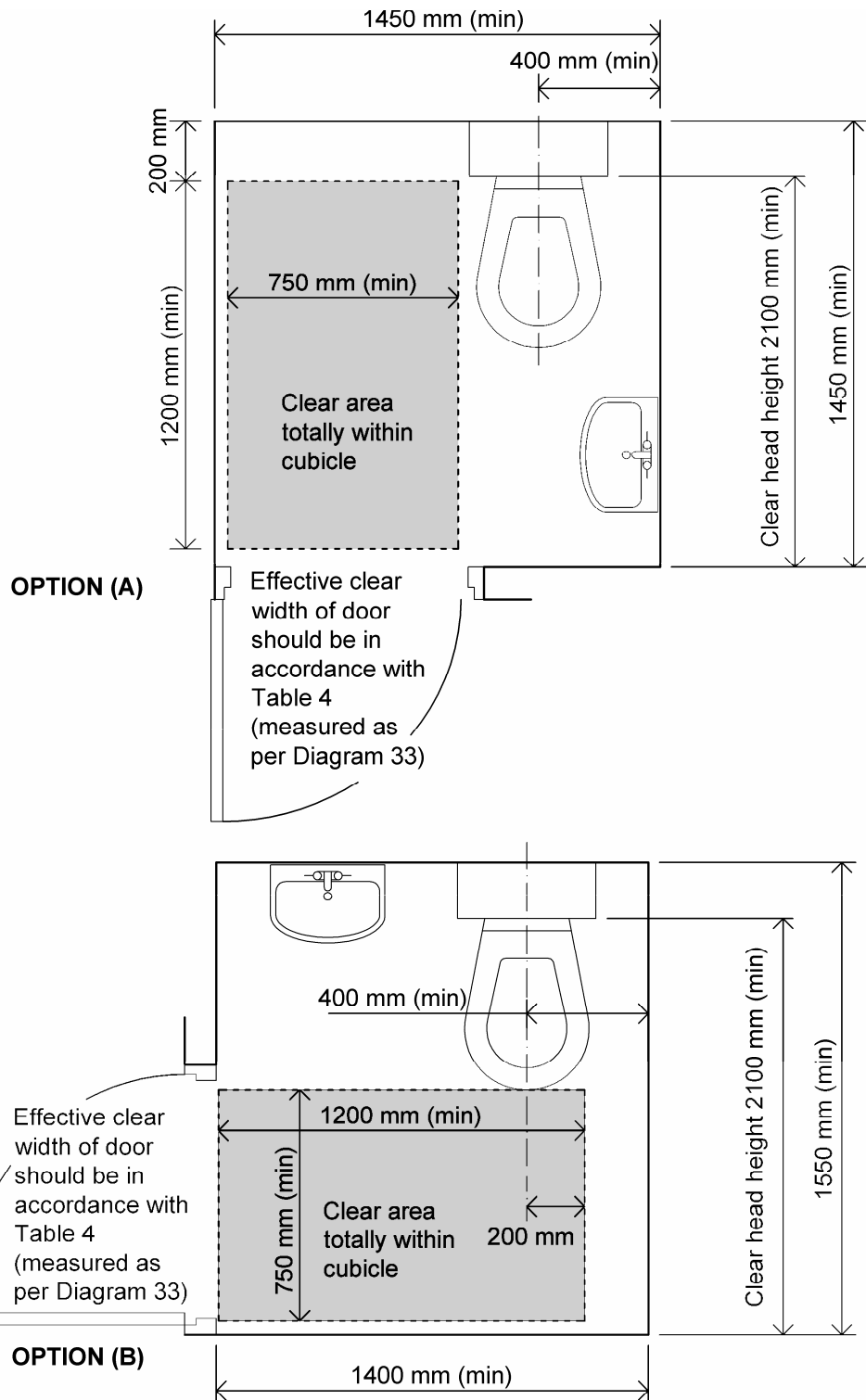

**NOTE:**

Washbasin may be located either within the space containing the WC or in an area adjacent to that space (Refer to Technical Guidance Document G).

The washbasin should be located so as not to impede access.

The overall dimensions should exclude such items as heat emitters, radiators, skirting boards, tiles and boxing in of pipework. Adjustments in room sizes may be needed to accommodate these items.

## Section 3.4

# Sanitary facilities for dwellings

### 3.4.3 WC in smaller dwellings

In the case of certain smaller dwellings, WC compartments in accordance with Diagram 35 are acceptable. This level of provision should only be considered where the area of the storey where the WC is located is less than 45 m<sup>2</sup>.

Diagram 35 shows an example of a possible layout for such a compartment.

The minimum effective clear width of a WC door should be in accordance with Table 4. However, the use of a door

opening wider than the minimum, an outward opening door, a folding door or a sliding door will generally assist in facilitating wheelchair access. The choice of door type and location should be such as not to pose undue hazard on a circulation route or be otherwise dangerous in use.

The minimum headroom available in the WC compartment should be 2100 mm measured from the front of the pan.

**Diagram 35 Example of WC compartment for small dwellings**

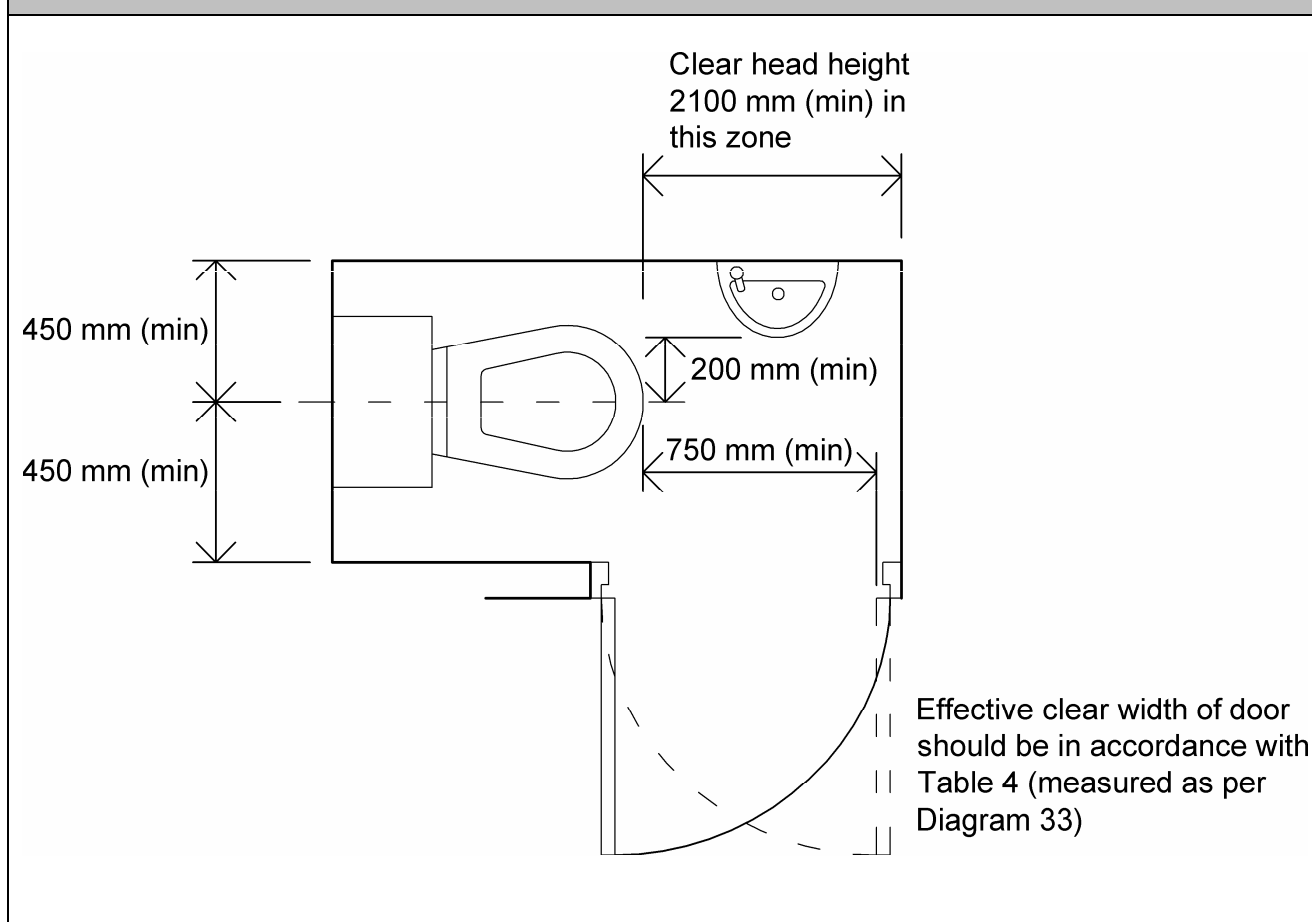

# Section 3.5

## Switches and sockets in dwellings

---

### Section 3.5

#### Switches and sockets in dwellings

##### 3.5.1 Objective

**The objective is that switches and socket outlets should be located at accessible heights and are easy to operate in the accessible areas of a dwelling.**

##### 3.5.2 Switches and sockets

Electric light switches in accessible areas should be located at a height between 900 mm to 1200 mm above floor level.

Equipment adjacent to the entry intended to assist in gaining entry, e.g. doorbells, entry phones, intercoms, should be located at a height between 900 mm and 1200 mm above floor level.

Switches and socket outlets for lighting and other equipment in accessible areas should be located at appropriate heights between 400 mm and 1200 mm from finished floor level.

These requirements are restricted to convenience socket-outlets used for general purposes and do not apply to dedicated socket outlets not readily accessible and used for appliances that are intended to be continuously connected in normal use.

The height requirements apply for all control devices in accessible areas except where the manufacturer's instructions specify otherwise.

# Standards and publications

---

## Standards referred to:

I.S. EN 1991-1-1:2002 - Eurocode 1: Actions on structures Part 1-1: General actions – densities, self weight, imposed loads for buildings (including Irish National Annex: 2005)

I.S. EN 81-1: 1999 Safety rules for the construction and installation of lifts - electric lifts (Amd 1) (+A3:2009)

I.S. EN 81-2:1999 Safety rules for the construction and installation of lifts - hydraulic lifts (Amd 1) (+A3:2009)

I.S. EN 81-70:2003 Safety rules for the construction and installation of lifts - Particular applications for passenger and good passenger lifts. Accessibility to lifts for persons including persons with disability (Amd A1:2005)

I.S. EN 997:2003 (+A1:2006) WC pans and WC suites with integral trap (AMD Corrigendum 14805) (AMD 16965)

BS 4800:1989 Paint colours for building purposes (whilst the colours in this standard cannot be seen on CD-ROM or online the text can still be used)

BS 6262:1982 Code of practice for glazing for buildings AMD 4063; AMD 4582; AMD 8279 (Partially superseded but remains current)

BS 6262-1:2005 Glazing for buildings Part 1 to Part 7

BS 6440:1999 Powered lifting platforms for use by disabled persons – Code of practice (partially superseded by BS EN 81-40:2008. The remainder of BS 6440:1999 will eventually be superseded by EN 81-41: 2009 Safety rules for the construction and installation of lifts – Special lifts for the transport of persons and goods - Part 41: Vertical lifting platforms intended for use by persons with impaired mobility)

BS 6571 - 4:1989 Vehicle parking control equipment- Part 4: Specification for barrier type parking control equipment

BS 7036-1:1996 Code of practice for Safety at powered doors for pedestrian use – Part 1. General

BS 7036-4:1996 Code of practice for Safety at powered doors for pedestrian use – Part 4. Low energy swing doors

BS 8300:2009 Design of buildings and their approaches to meet the needs of disabled people – Code of practice

BS 8493:2008 (+A1:2010): Light reflectance value (LRV) of a surface - Method of test

BS 8501:2002 Graphic symbols and signs – Public information symbols (AMD 16897)

# Standards and publications

---

IEC 60118-4:2006 Electroacoustics. Hearing aids. Induction loop systems for hearing aid purposes. Magnetic field strength (ISBN 978 0 580 50047 3)

## **Publications referred to:**

Accessible Stadia – Sports Ground and Stadia Guide No.1 - A good practice guide to the design of facilities to meet the needs of disabled spectators and other users.

[www.nads.org.uk](http://www.nads.org.uk)

Accessible thresholds in new housing, Guidance for house builders and designers (1999) Department of the Environment, Transport and the Regions. The Stationery Office, The Publications Centre, PO Box 276, London SW8 5DT

Architectural Heritage Protection – guidelines for planning authorities – Planning Guidelines No.9, Dept of the Environment, Heritage and Local Government

Building for Everyone – A Universal Design approach (2010 edition), National Disability Authority, 25 Clyde Road, Ballsbridge, Dublin 4. [www.nda.ie](http://www.nda.ie)

Good Practice Guidelines on Accessibility of Streetscapes, Local Government Management Services Board (LGMSB), Local Government House, 35 – 39 Ushers Quay Dublin 8

Guidelines for Public Access Terminals, National Disability Authority, 25 Clyde Road, Ballsbridge, Dublin 4, [www.nda.ie](http://www.nda.ie)

Sustainable Urban Housing: Design Standards for New Apartments - Guidelines for Planning Authorities, Dept of the Environment, Heritage and Local Government

Traffic Signs Manual – Department of the Environment 1996 (New edition due to be published in 2010 by the Department of Transport)

# Other standards and publications

---

## **Legislation**

Disability Act 2005

Equal Status Act 2000 - 2008

Employment Equality Acts 1998 and 2004

Building Control Act 2007

Building Regulations 1997-2010

Safety, Health and Welfare at Work (General Application) Regulations 2007 (S.I. No. 299 of 2007)

Lift Directive 95/16/EC

Machinery Directive 2006/42/EC

## **General Accessibility**

BS 8300:2009 Design of buildings and their approaches to meet the needs of disabled people – Code of practice

Centre for Excellence in Universal Design [www.universaldesign.ie](http://www.universaldesign.ie)

Building for Everyone – A Universal Design approach (2010 edition), National Disability Authority, 25 Clyde Road, Ballsbridge, Dublin 4 [www.nda.ie](http://www.nda.ie) (currently under review)

Best Practice Access Guidelines, Designing Accessible Environments, Irish Wheelchair Association, Áras Chúchulainn, Blackheath Drive, Clontarf, Dublin 3. [www.iwa.ie](http://www.iwa.ie)

Designing for Accessibility, Andrew Lacey 2004, Centre of Accessible Environments and RIBA Publishing, Centre for Accessible Environments and the Access Lab, 70 South Lambeth Road, London SW8 1RL, [www.cae.org.uk](http://www.cae.org.uk) (ISBN 1 85946 143 3)

Designing for people with sensory impairments, Stephen Thorpe Access Committee for England, 1986 (ISBN 090397617X)

The Accessible Office. JUM Access Partnership, Royal National Institute of Blind People, 105 Judd Street, London, WC1H 9NE, [www.rnib.org.uk](http://www.rnib.org.uk)

## **Approach and Access**

Accessible thresholds in new housing, Guidance for house builders and designers (1999) Department of Environment, Transport and the Regions. The Stationery Office, The Publications Centre, PO Box 276, London SW8 5DT

DD CEN/TS 15209:2008 Tactile paving surface indicators produced from concrete, clay and stone (This document is a draft for development and replaces BS 7997:2003)

# Other standards and publications

---

## **Circulation**

I.S. EN 81-1: 1999 Safety rules for the construction and installation of lifts - electric lifts (Amd 1) (+A3:2009)

I.S. EN 81-2:1999 Safety rules for the construction and installation of lifts - hydraulic lifts (Amd 1) (+A3:2009)

I.S. EN 81-70:2003 Safety rules for the construction and installation of lifts - Particular applications for passenger and good passenger lifts. Accessibility to lifts for persons including persons with disability (Amd A1:2005)

I.S. EN 10535: 1998 Hoist for the transfer of Disabled Persons

BS 6440:1999 Powered lifting platforms for use by disabled persons – Code of practice (partially superseded by BS EN 81-40:2008. The remainder of BS 6440:1999 will eventually be superseded by EN 81-41: 2009 Safety rules for the construction and installation of lifts – Special lifts for the transport of persons and goods - Part 41: Vertical lifting platforms intended for use by persons with impaired mobility)

Automatic Door Systems, Alison Grant 2005, Centre for Accessible Environments and the Access Lab, 70 South Lambeth Road, London SW8 1RL, [www.cae.org.uk](http://www.cae.org.uk) (ISBN 1 85946 171 9)

## **Sanitary facilities**

Good Loo Design Guide, Andrew Lacey 2004, Centre of Accessible Environments and RIBA Publishing, Centre for Accessible Environments and the Access Lab, 70 South Lambeth Road, London SW8 1RL [www.cae.org.uk](http://www.cae.org.uk), (ISBN 1 85946 144 1)

## **Facilities**

Accessible Stadia – Sports Ground and Stadia Guide No.1 - A good practice guide to the design of facilities to meet the needs of disabled spectators and other users.  
[www.nads.org.uk](http://www.nads.org.uk)

Accessible Sports Facilities formerly known as Access for Disabled People, Updated Guidance 2010, Sport England Publications, PO Box 255, Wetherby, LS 237LZ, [www.sportengland.org](http://www.sportengland.org)

ET101:2008 National Rules for Electrical Installations, Electro Technical Council of Ireland

## **Communication aids**

BS 4800:1989 Paint colours for building purposes (whilst the colours in this standard cannot be seen on CD-ROM or online the text can still be used)

BS 7594:1993 Code of Practice for audio-frequency induction loop systems (AFILS)

BS 5252:1976 Framework for colour co-ordination for building purposes

# Other standards and publications

---

IEC 60118-4:2006 Electroacoustics. Hearing aids. Induction loop systems for hearing aid purposes. Magnetic field strength (ISBN 978 0 580 50047 3)

Guidelines for Public Access Terminals, National Disability Authority, 25 Clyde Road, Ballsbridge, Dublin 4, [www.nda.ie](http://www.nda.ie)

Access to ATMs: UK design guidelines Robert Feeney, 2002, Centre for Accessible Environments and the Access Lab, 70 South Lambeth Road, London SW8 1RL, [www.cae.org.uk](http://www.cae.org.uk) (ISBN 0 903976 33 1)

Building Sight, Peter Barker, Jon Barrick and Rod Wilson, HMSO in association with the Royal National Institute for the Blind, 1995 <http://onlineshop.rnib.org.uk> (ISBN 1 85878 074 8)

Sign Design Guide – a guide to inclusive signage, 2000, Peter Barker and June Fraser, JMU and the Sign Design Society, [www.jmuaccess.org.uk](http://www.jmuaccess.org.uk) (ISBN 185878 412 3)

See it right - Signage, 2007, Royal National Institute of Blind People, 105 Judd Street, London WC1H 9NE, [www.rnib.org.uk](http://www.rnib.org.uk)

Good Signs – Improving signs for people with a learning disability, Disability Rights Commission, 2004, [www.drc.gov.uk](http://www.drc.gov.uk)

Code for Interior Lighting, Chartered Institute of Building Service Engineers, CIBSE, 1997, [www.cibse.org](http://www.cibse.org)

Project Rainbow, the Research Group for Inclusive Environments, 1995-1996, University of Reading, [www.rdg.ac.uk](http://www.rdg.ac.uk)

Colour Contrast and Perception (2004) 2<sup>nd</sup> Edition, Keith Bright et al, The Research Group for inclusive Environments, The University of Reading, UK. [www.keithbrightconsultants.com](http://www.keithbrightconsultants.com)

## **Dwellings**

Housing Design Guidelines for Occupational Therapists (2007) Association of Occupational Therapists of Ireland, [www.aoti.ie](http://www.aoti.ie), (ISBN 978-0-9555053-1-7)

## **Egress**

Promoting Safe Egress and Evacuation of People with Disabilities, National Disability Authority, 25 Clyde Road, Dublin 4, [www.nda.ie](http://www.nda.ie)

BS 5588-8:1999 Fire precautions in the design, construction and use of buildings. Code of practice for means of escape for disabled people



# Other standards and publications

---

## **Historic buildings**

Advice Series: Access – improving the accessibility of historic buildings and places, Department of the Environment, Heritage and Local Government (publication pending)

Architectural Heritage Protection – guidelines for planning authorities – Planning Guidelines No.9, Department of the Environment, Heritage and Local Government

Access to the Historic Environment - Meeting the Needs of Disabled People, Usa Foster, Donhead Publishing Ltd., Lower Coombe, Donhead St. Mary, Shaftesbury, Dorset, SP7 9LY, England (1997)

Easy Access to Historic Buildings, by English Heritage, second edition 2005, [www.english-heritage.org.uk](http://www.english-heritage.org.uk)

Code of Practice on Accessible Heritage Sites, National Disability Authority, 25 Clyde Road, Dublin 4, [www.nda.ie](http://www.nda.ie) (publication pending)

## **Existing buildings**

Buildings for All to Use 2- improving the accessibility of public buildings and environments (CIRIA C610), Construction Industry Research and Information Association, Classic House, 174 - 180 Old Street, London EC1V 9BP, UK [www.ciria.org](http://www.ciria.org) (ISBN 0 86017 610X)

## **Management**

Access Handbook Template- A Tool to Help Manage the Accessibility of the Built Environment, National Disability Authority, 25 Clyde Road, Ballsbridge, Dublin 4. [www.nda.ie](http://www.nda.ie)

The Access Manual -auditing and managing inclusive built environments, Second Edition, Ann Sawyer and Keith Bright, Blackwell Publishing, [www.blackwellpublishing.com](http://www.blackwellpublishing.com), (ISBN 9781405146265)